

# EcoMultiCyclone

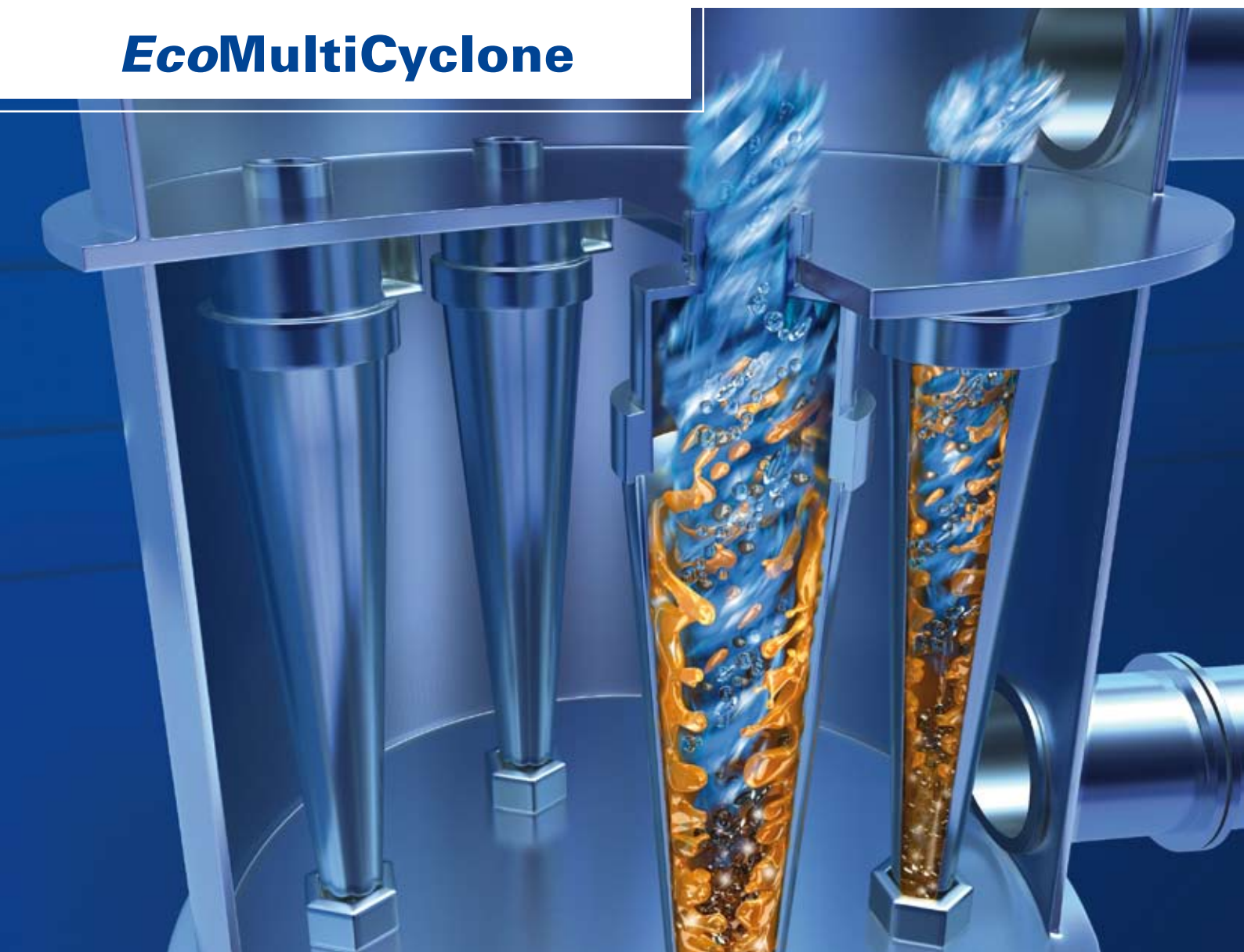

Maximum Filtration – Minimal Costs



Technologies · Systems · Solutions

# EcoMultiCyclone – Cost Reductions through Quality Increases

**EcoMultiCyclone** is a separation system which is used in the automobile industry for the removal of solid matter particles in the degreasing and rinsing zones of pretreatment baths. Furthermore, the cyclone can also be used in other branches. Via integrative interfaces it can be optimally installed in the recirculation of these process zones. Process quality is increased through an optimized separation performance of liquids and solids. **EcoMultiCyclone** shows its strength with its effective filtration performance and reduces dirt burden in the entire installation periphery.

With **EcoMultiCyclone** you are designing your degreasing and rinsing process in a quality oriented manner. At the same time you are reducing unit costs, among other things due to the conservation of chemicals and energy. The **EcoMultiCyclone** brand name stands for an innovative, economically efficient and ecological product, with simple functionality and low maintenance.

## **EcoMultiCyclone offers the following advantages:**

- Filtration with highest efficiency and effectiveness
- Removal of large and small solid matter in the degreasing and rinsing zones
- Increase in process quality
- Reduction of manual reconditioning
- Increase in bath usage times
- Reduction in chemical usage
- Lowering of operation and maintenance costs
- Minimal space requirements
- Optimal passage size of intake and drainage



## **EcoMultiCyclone – modular technology which is worthwhile**

The cyclone is a mechanical separator without movable internal parts, of which all elements and materials have been developed by Dürr. Versions are available in both normal or stainless steel. Depending on requirements **EcoMultiCyclone** is equipped with either 12 cyclone elements made of abrasion secure plastic and has a throughput volume of 120 m<sup>3</sup>/h or in a smaller design with 6 elements and a throughput volume of 60 m<sup>3</sup>/h. No opening in the system falls short of a diameter of 25 mm, that way the filter is not prone to blockages.

The investment in the Dürr **EcoMultiCyclone**, in which a particle size > 40 µm and a particle concentration of 2,7 g/cm<sup>3</sup> reaches a separation performance of 100%, typically amortizes itself in less than 2 and a half years.

## **300% quality increase in comparison to typical filter systems with:**

- ▶ 30% investment savings
- ▶ 33% energy savings

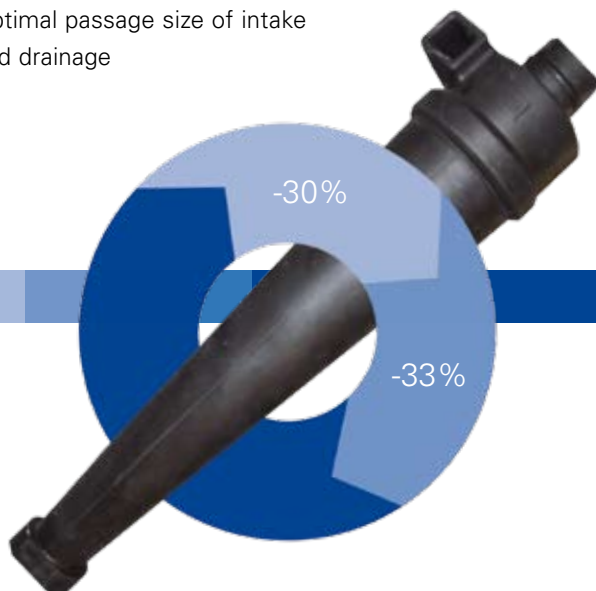

## EcoMultiCyclone – process optimizing to ensure your quality

**EcoMultiCyclone** is located in the recovery circulation of the treatment zone. The process solution flows through the intake into the cyclone element and continually circulates through the **EcoMultiCyclone**, through which the solid matter is removed from the bath solution.

Once the process solution has flowed through the intake of the coned cyclone element, the separation of solid material, including solder scoriae and sanding particles takes place via centrifugal force. Removed solid material collects in the lower part of the housing and is frequently removed to the band-pass filter.

With the high filtration efficiency it is possible to immediately reintroduce the recovered process liquid back into the treatment zone. With **EcoMultiCyclone** process quality is continually improved.

### EcoMultiCyclone ensures:

- Efficient solution recovery
- Increased life cycle of filter bag
- Protection against soiling of spray system and nozzles
- Less dirt exposure to the heat exchanger
- Reduction in dirt carryover in the following zones

## EcoMultiCyclone proves itself in comparison to conventional cyclone filters:

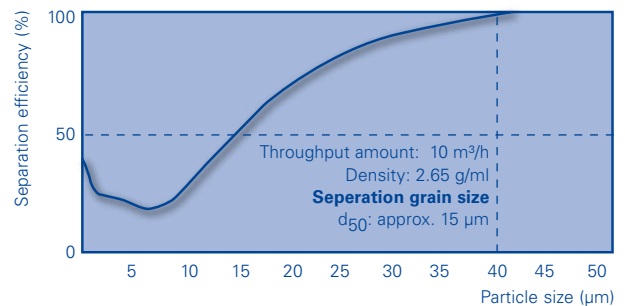

### Additionally, unit costs are reduced through:

- Less reconditioning
- Lower operation and maintenance costs
- Increasing of bath usage times
- Less chemical usage
- Less nozzle replacements
- Increased heat exchanger filter bag life cycle

Dürr helps you to reduce your costs, to maximize your filtration and to increase your process quality. In addition to the initial fitting we offer you the refitting of all existing pretreatment installations.

Our service team, with service points around the globe, offers you fast and quality oriented solutions.

Implementation of **EcoMultiCyclone** is also possible outside of the automobile industry – just ask us!

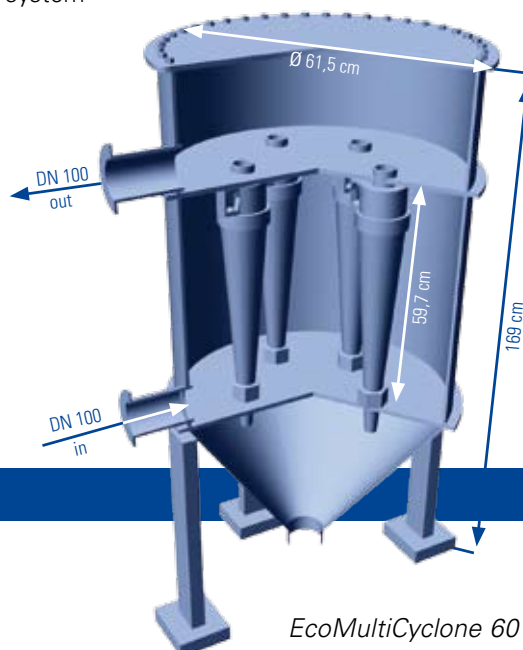

EcoMultiCyclone 60 m<sup>3</sup>/h

# EcoMultiCyclone

## Your competitive edge with Dürr:

- Efficiency – minimal costs with maximum filtration capacity
- Effectiveness – increasing your process quality
- Interfaces and process knowledge of highest level
- Simple functionality and low maintenance
- Securing of stable value of your products
- Competitive edge in technology with an innovative product
- With each and every unit produced you save on cost per unit!

Paint and Final Assembly Systems • [www.durr.com](http://www.durr.com)



Technologies · Systems · Solutions