

LEADING IN
PRODUCTION
EFFICIENCY

A close-up photograph of industrial machinery. A metallic nozzle with a blue ribbed section is dispensing a white adhesive onto a dark, curved metal component. The background is blurred, showing other parts of the machine.

Automation solutions for glazing and battery cover gluing

10. October 2019
Bietigheim-Bissingen

Dürr Systems AG, Michael Zoeller

1. Testcenter
2. Overview
3. Example Layout for Battery Box or Glasses
4. Products for the Processes
5. References



1

Testcenter

Testcenter



Our customer cestcenter Europe – a service for you in Bietigheim-Bissingen

Gluing tower station

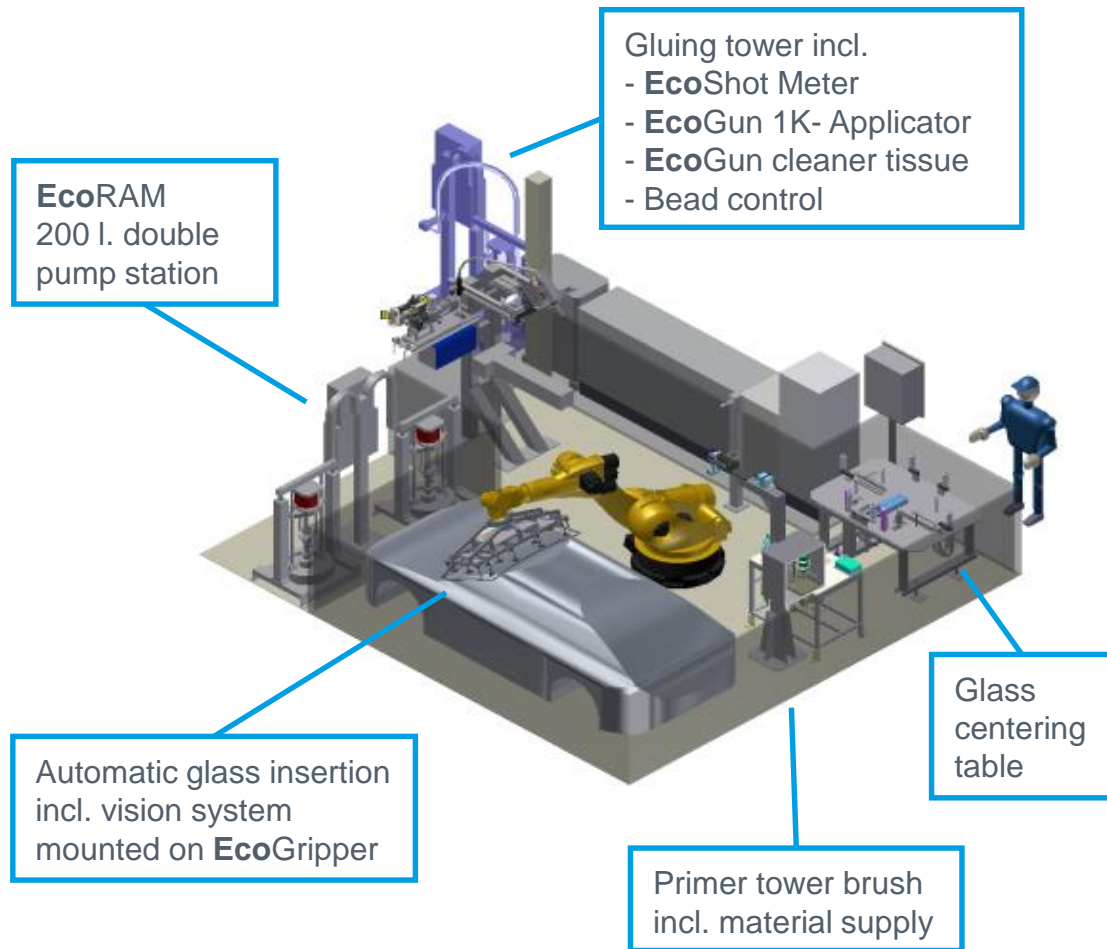

Robot application station

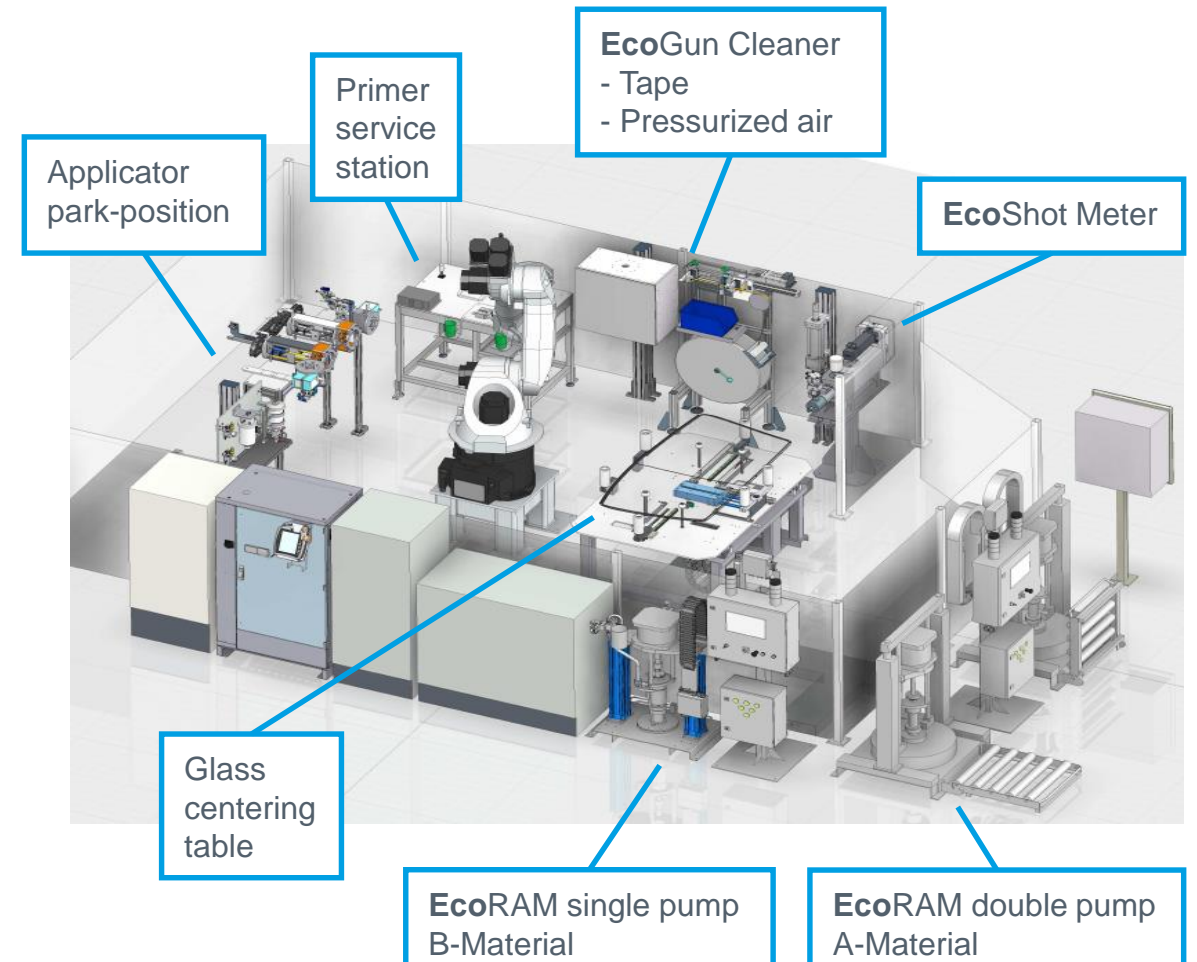

Testcenter



Our customer testcenter China – a service for you in Shanghai



- Process development and validation tests for gluing
- Development of customer-specific solutions
- Process optimization



- 2 compact automatic gluing cells

2

Overview

Overview

Examples for application parts

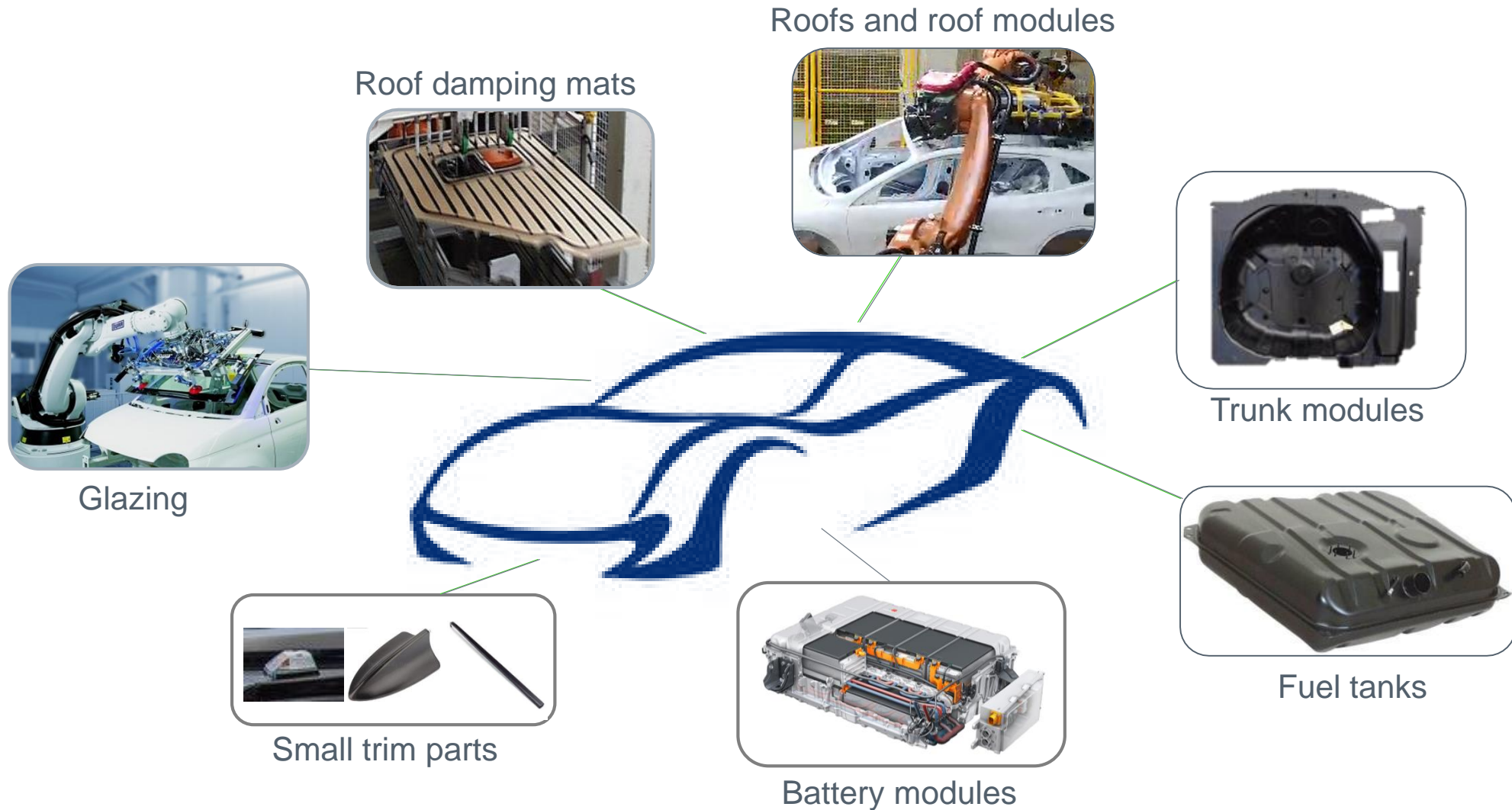

Overview

Parts handling and materials application

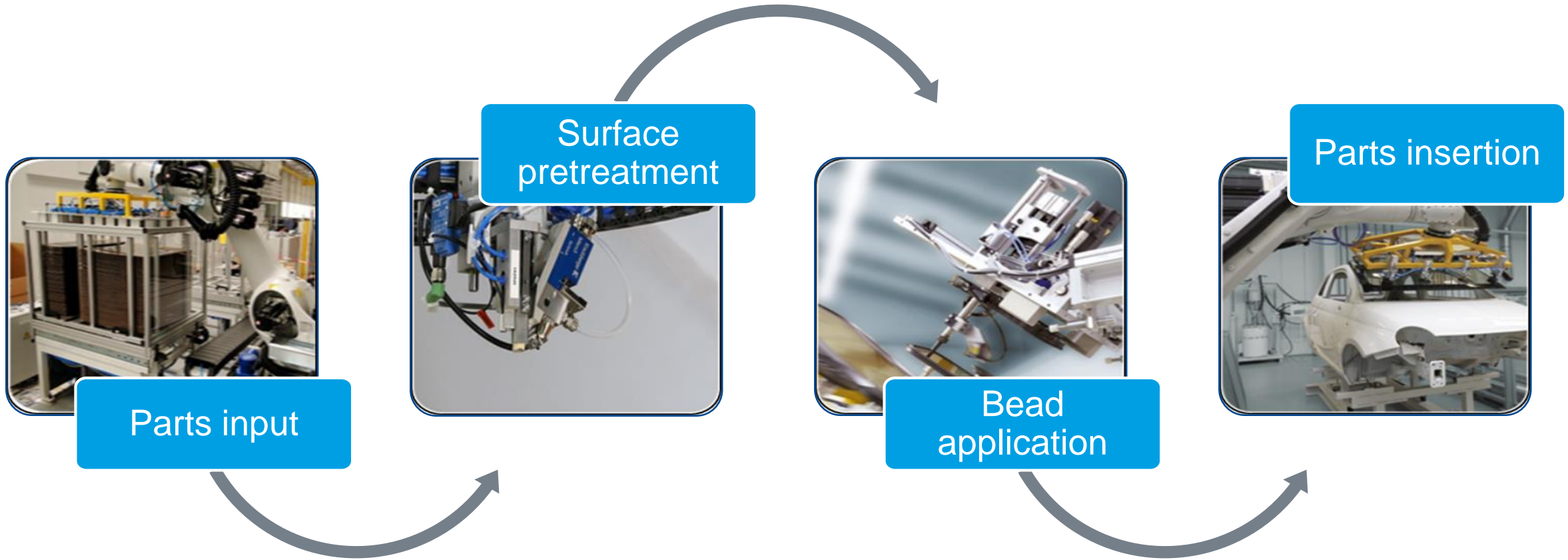

Turnkey gluing cell

incl. controls system / HMI / safety equipment / process control / vision system / interfaces (conveyor, plant network, ...)

3

**Example Layout for Battery
Box or Glasses**

Example Layout for Battery Box or Glazing



Typical applications of an automated assembly line

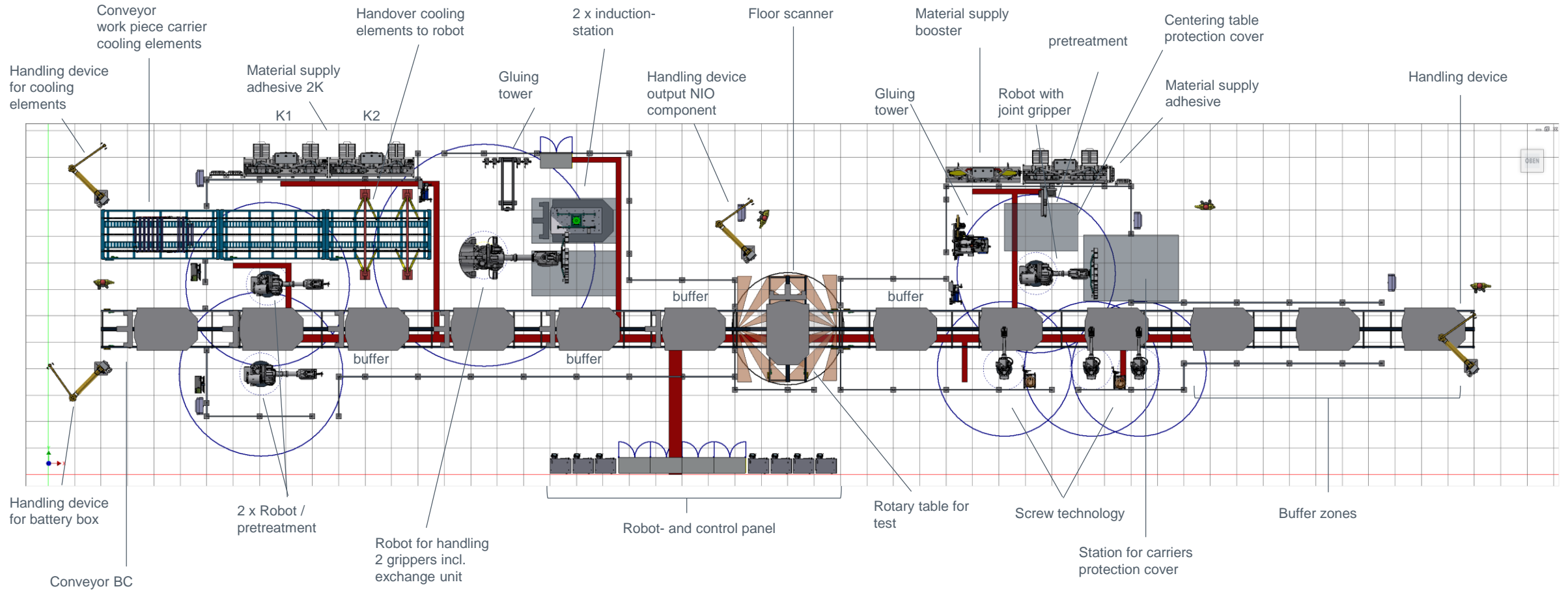

Products for the Processes

Overview



Application technology

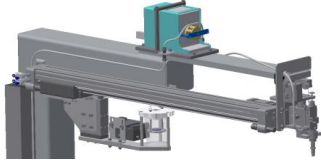

Pretreatment

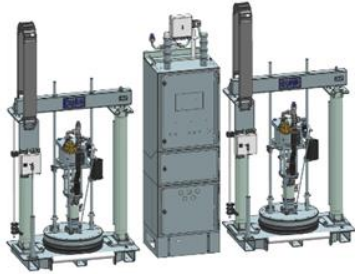

Material supply

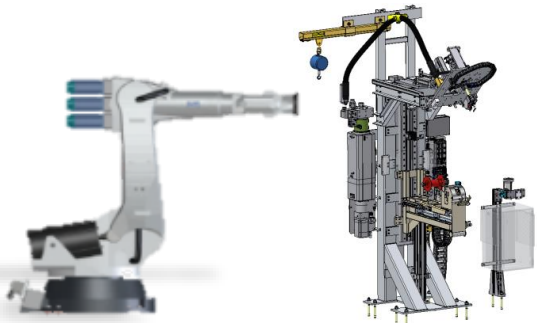

Robot and gluing tower

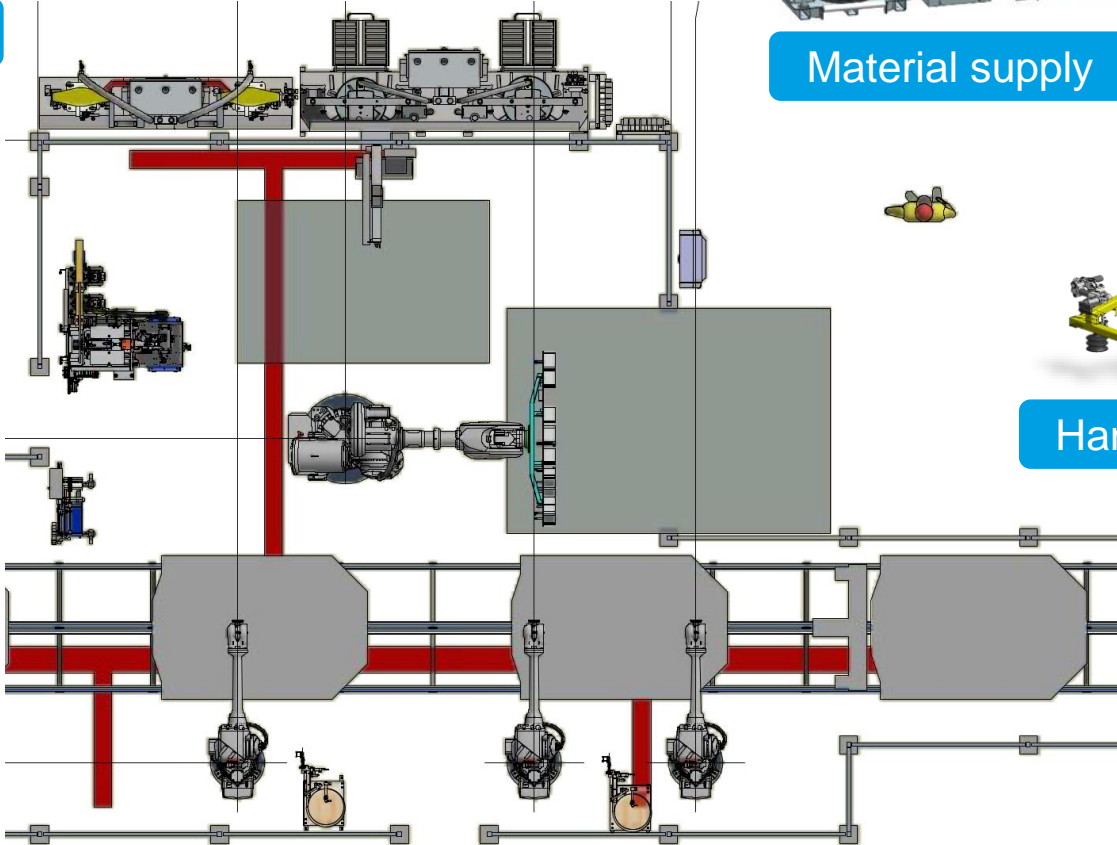

Handling technology



Control- and visu-system

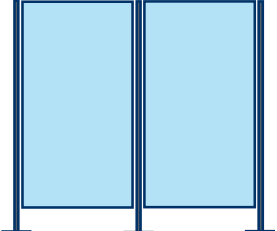

Cell safety

4

Products for the Processes

Products for the Processes



Pretreatment

Spray-application

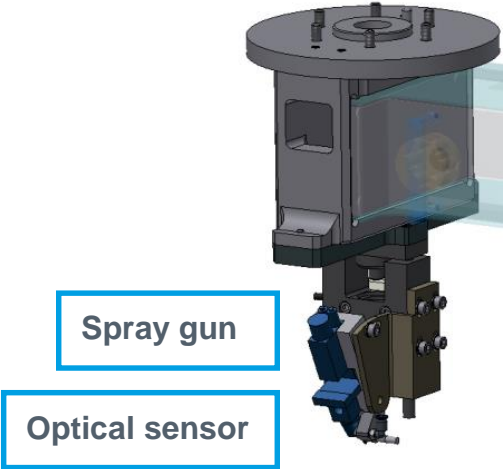

Spray-felt-application

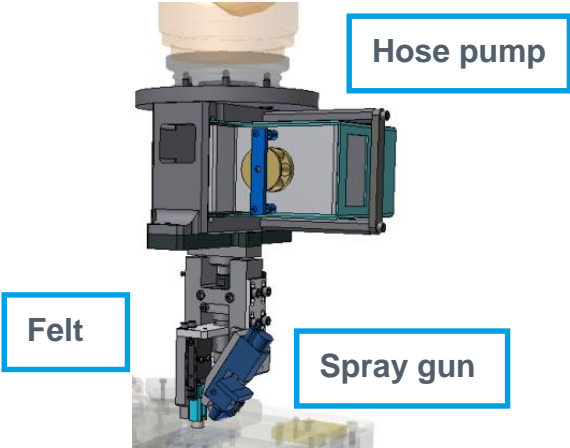

Material supply cleaner/activator/primer

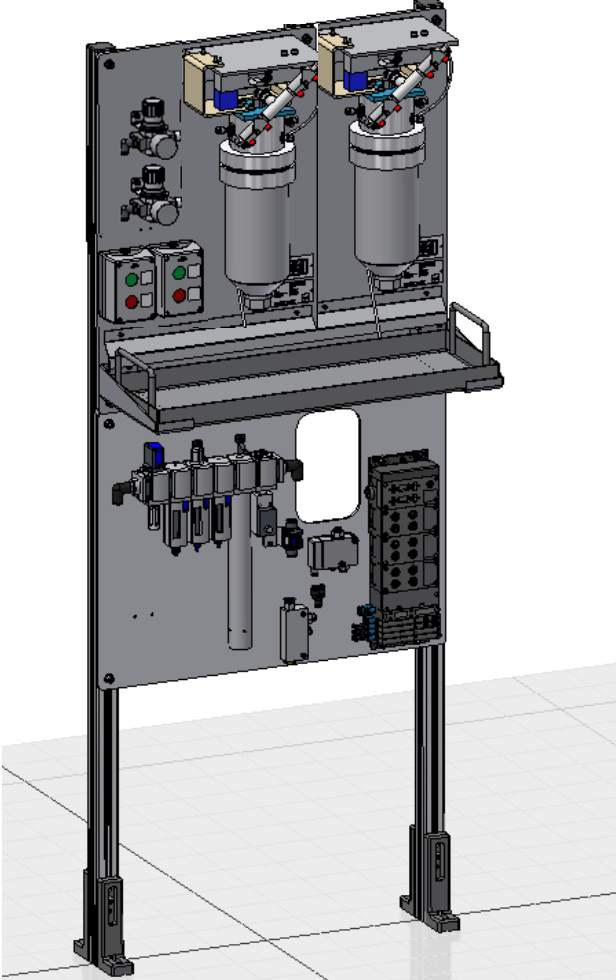

Felt-application

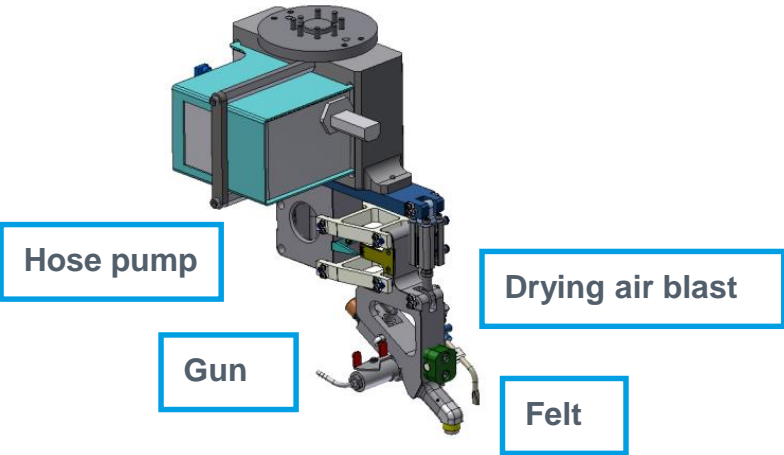

Brush-application

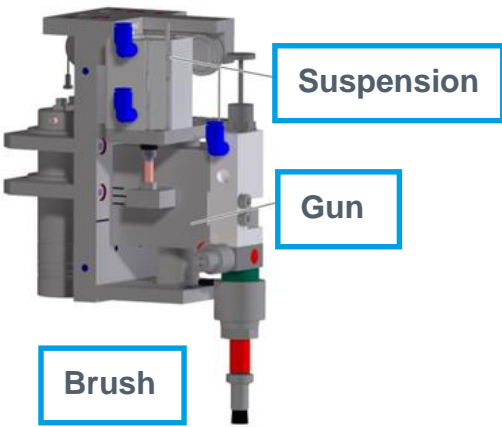

Products for the Processes

Pretreatment

1. Feeding device incl. light sensor felt
2. Light sensor - felt in application head (presence yes/no)
3. Humidity sensor
4. Clamping device for used felts
5. Box for used felts
6. Scale for quality control
7. Cup holder for flushing and quality control (flow amount)

FELT-service-station

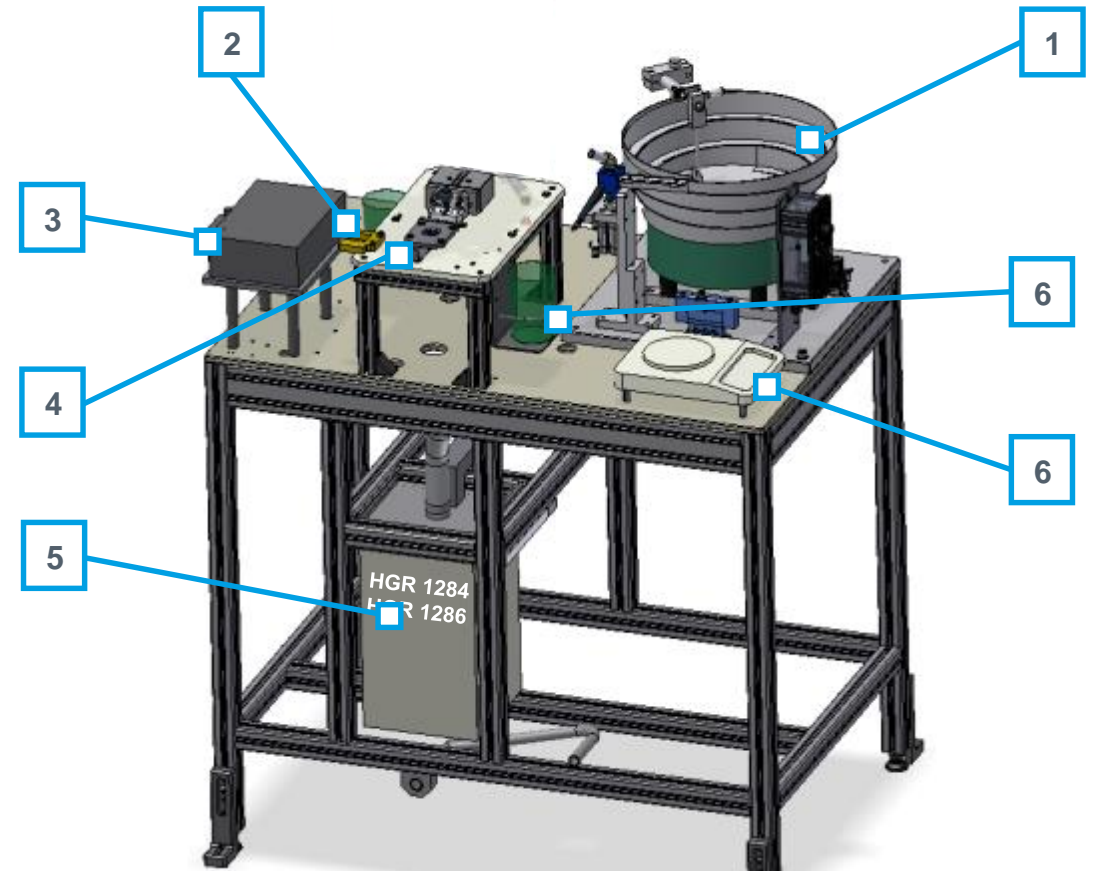

Products for the Processes

Glue applicators

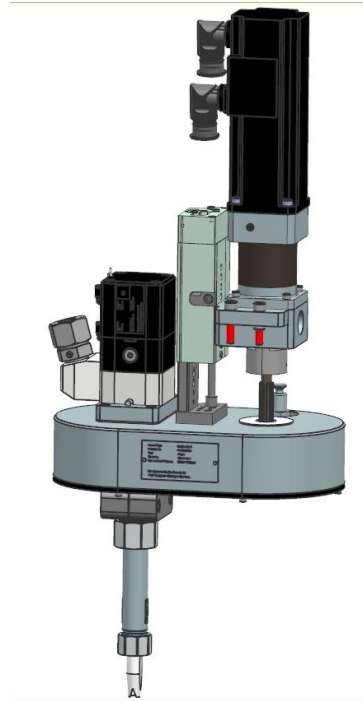
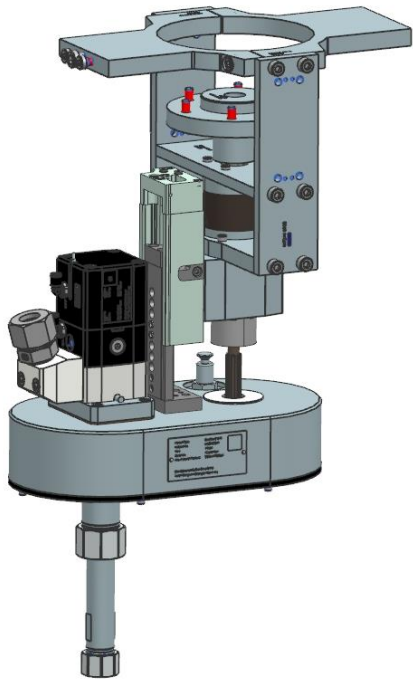

EcoGun applicators on robot or tower

Technical data	unit	EcoGun2 PVA 08
Pneumatic supply pressure min	bar	4,5
Pneumatic operation pressure	bar	5
Operation material pressure	bar	360
Max. temperature range	°C	80
Compensation Z-axis	mm	+ - 20
Gear ratio		1:3 / 10:1
Width	mm	290
Depth	mm	170
Height	mm	585
Weight	kg	~18

Products for the Processes

Gluing tower incl. nozzle cleaning systems



Nozzle cleaning by tissue system

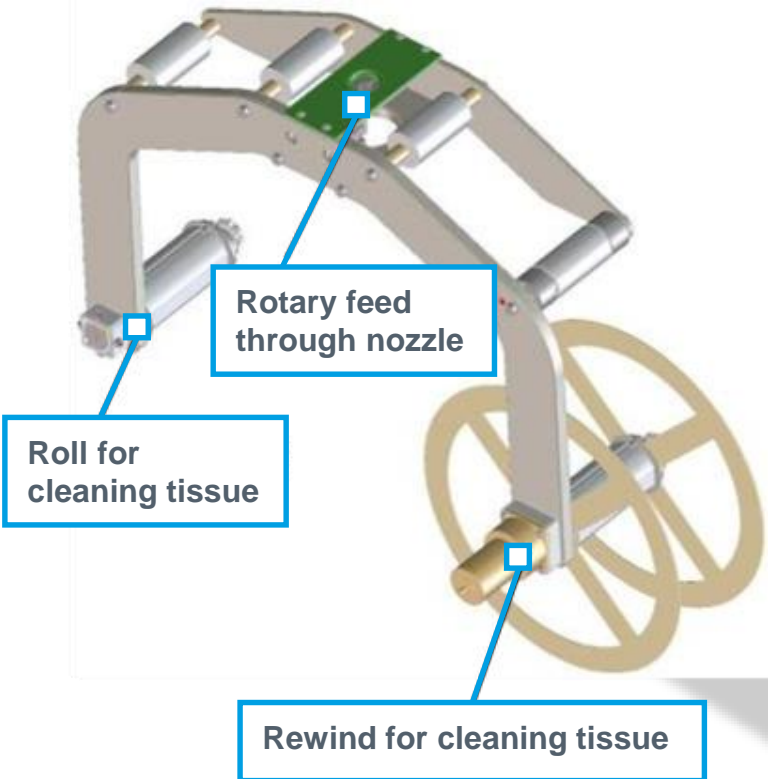
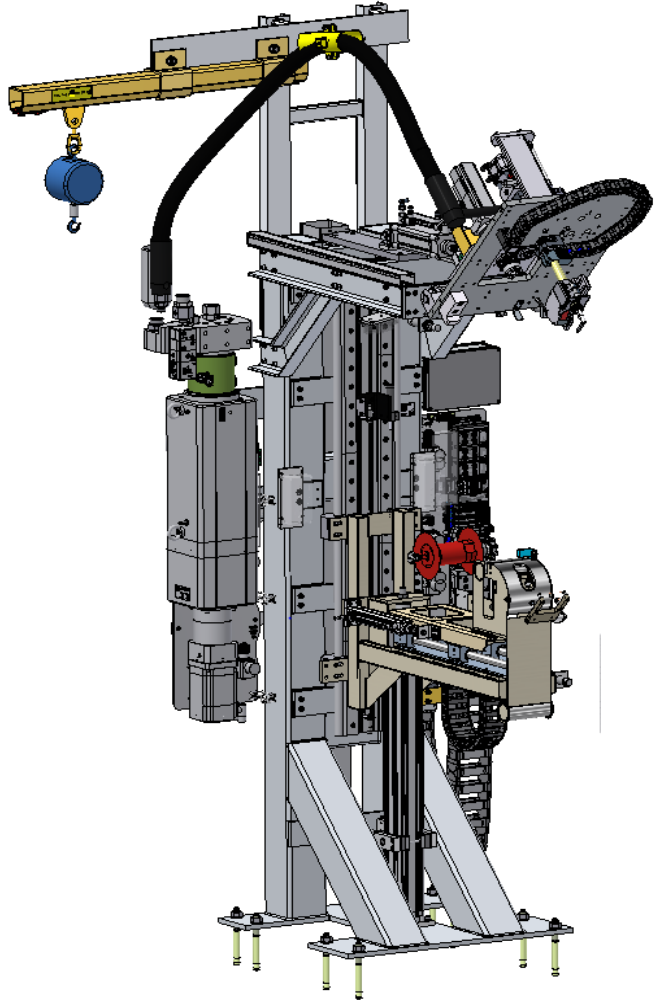

Nozzle cleaning by air blower system

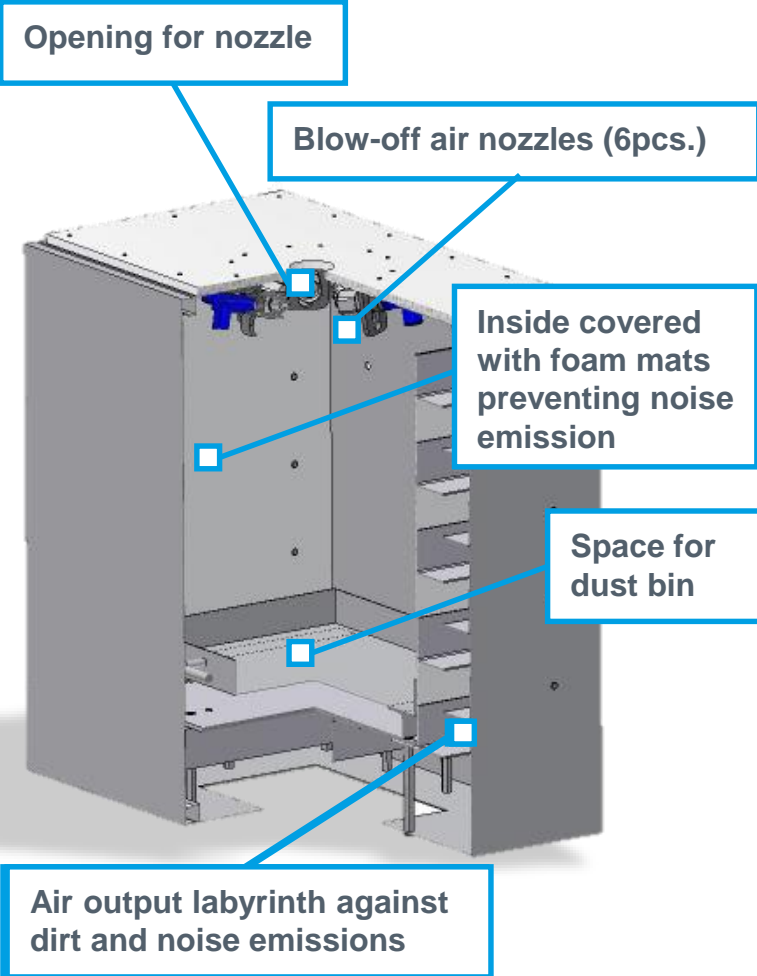

Products for the Processes

Gluing tower incl. nozzle cleaning systems



Nozzle cleaning by tape system

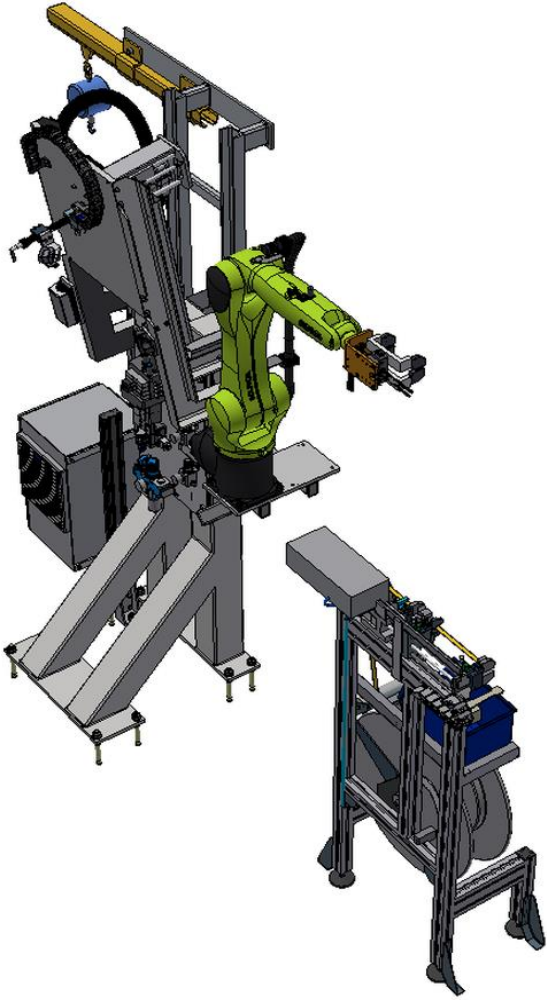
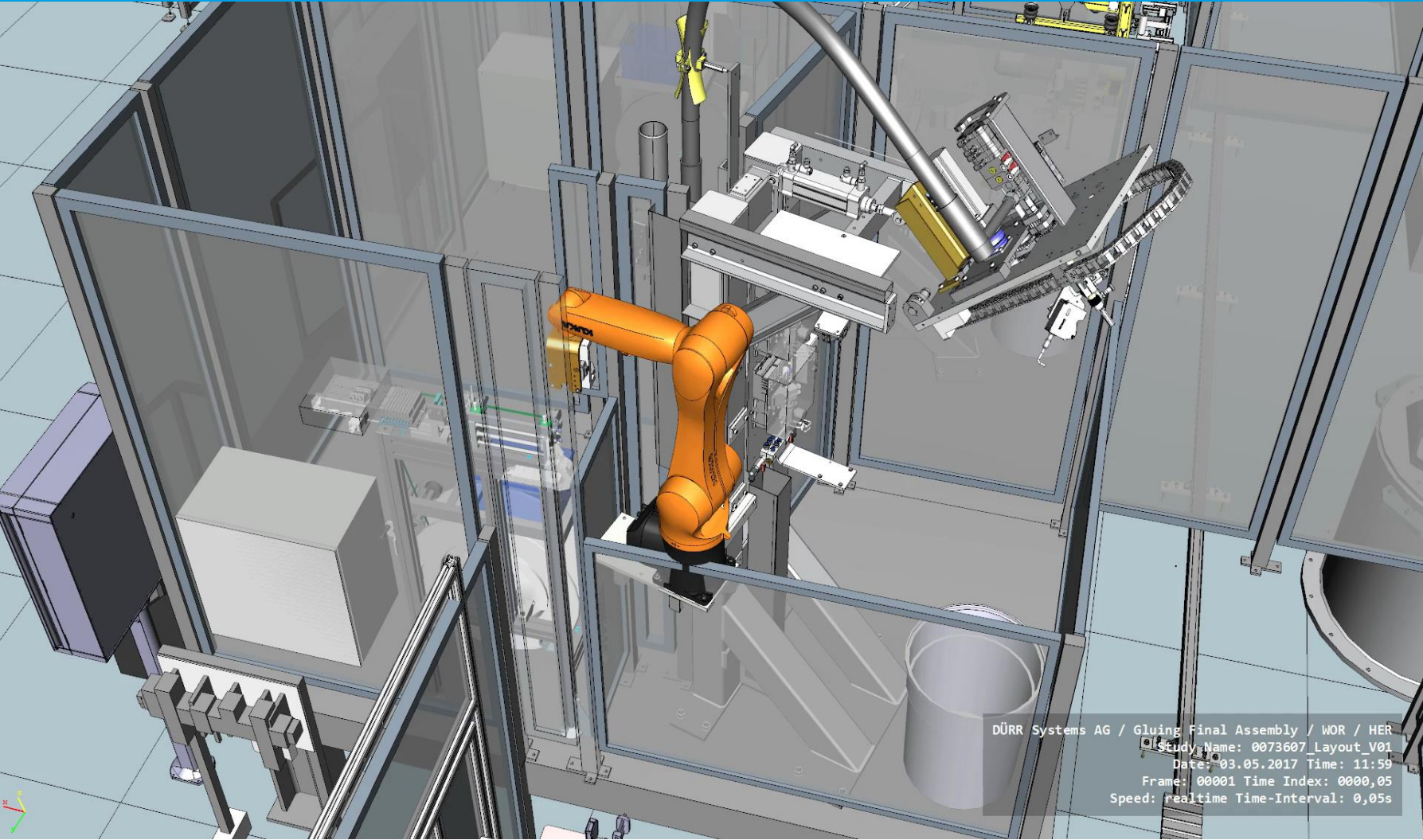

Products for the Processes

Examples for parts handling, centering, gripping



Centering station with drawer / shuttle

Conveyor incl. centering station

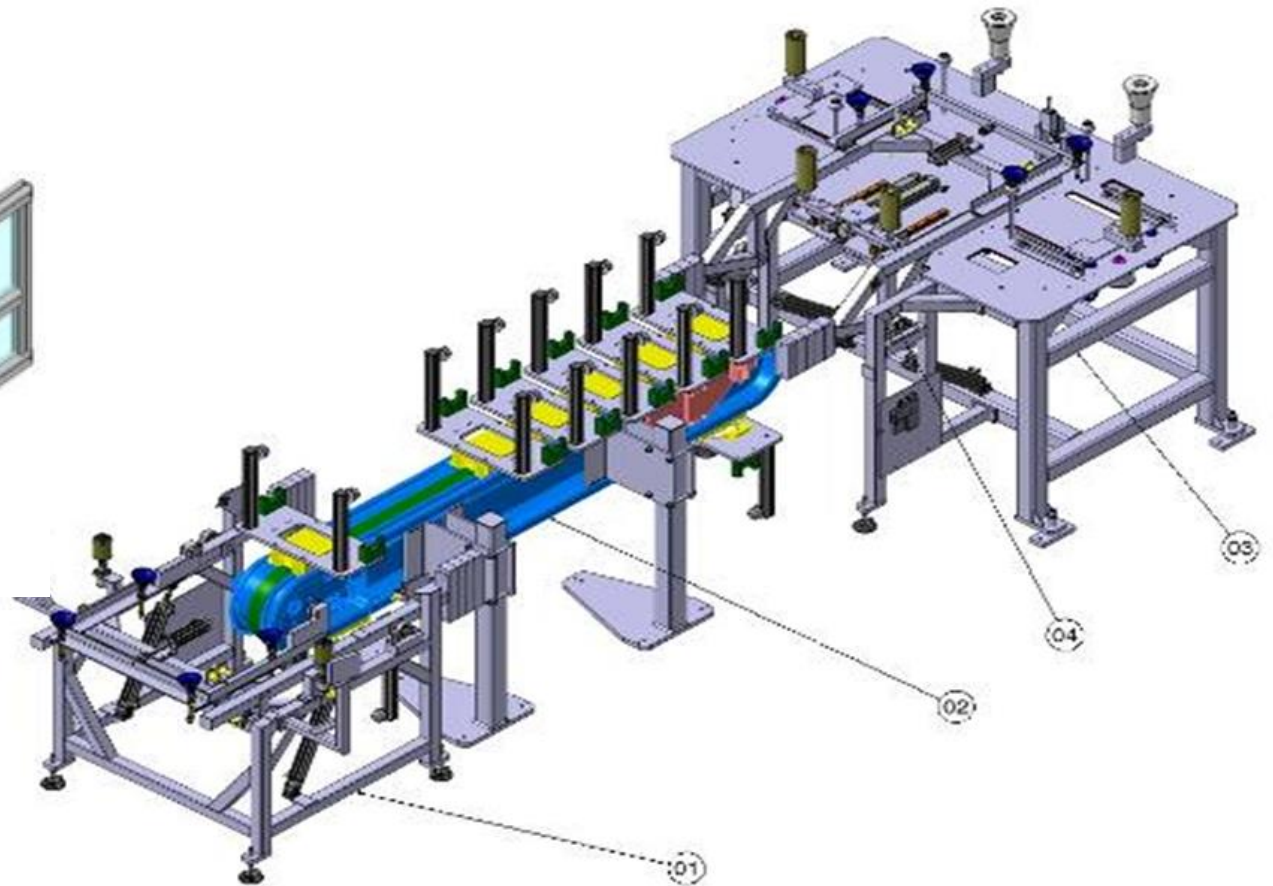
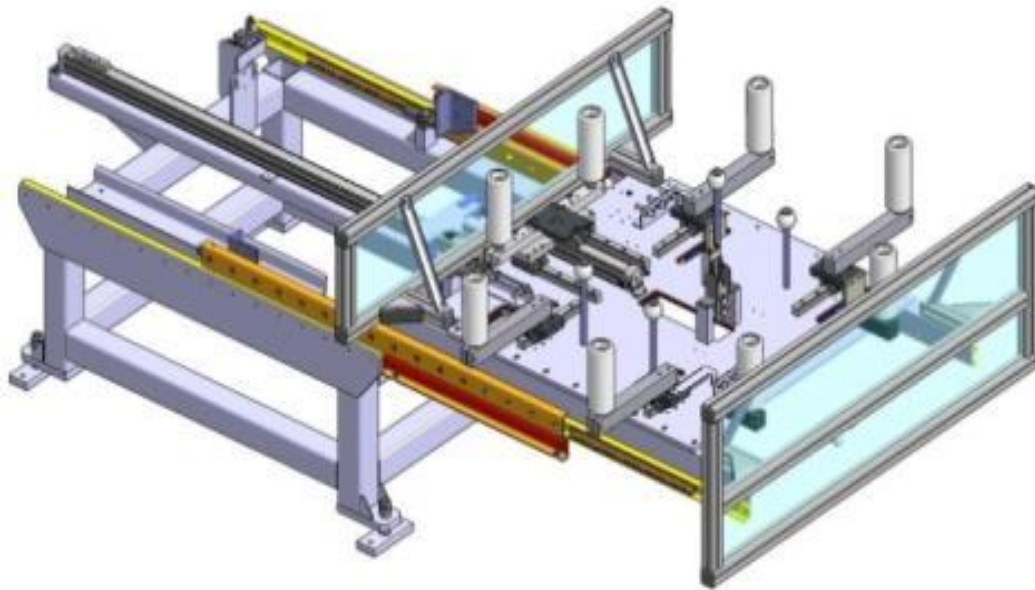

Products for the Processes

Examples for parts handling, centering, gripping



Flexible robot gripper for different part shapes

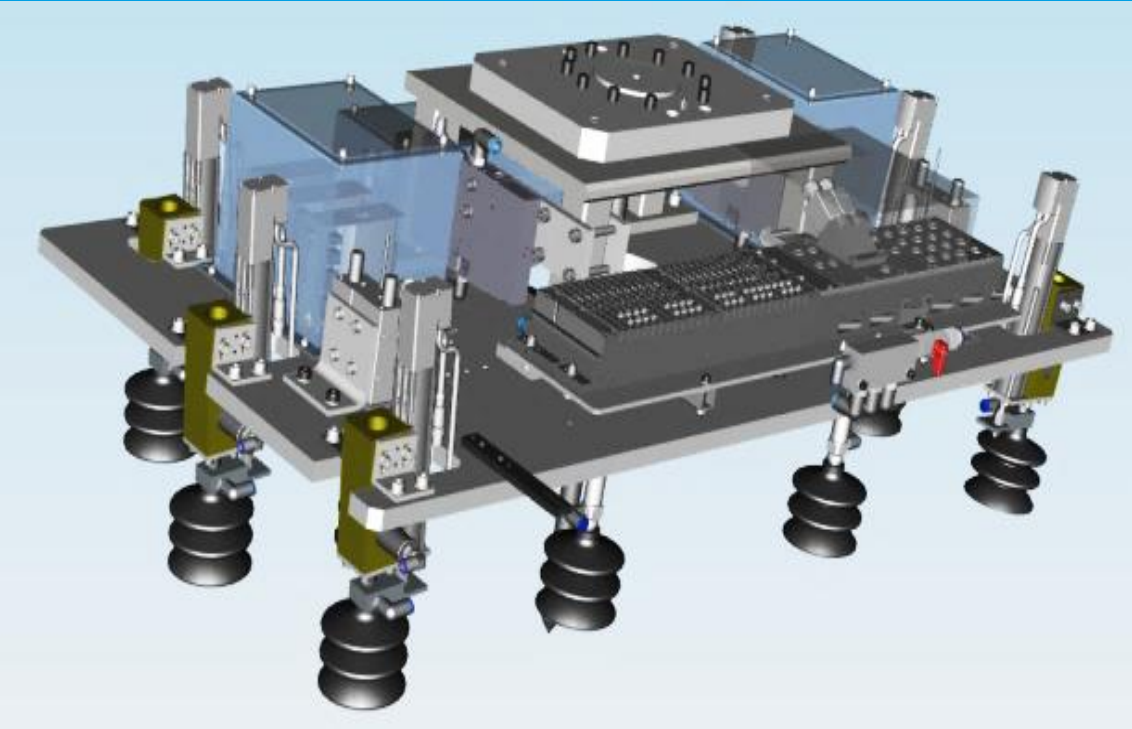

Robot gripper with vision camera system

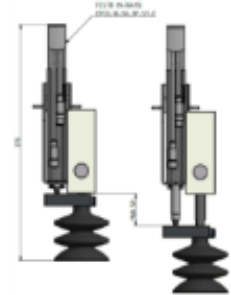

Vacuum suction cups with automated controlled positions

5

References

References

CAF Chongqing panoramic glass roof assembly



References



BMW Human Robot Collaboration assembly of PHEV-tank and GPS antenna



LEADING IN
PRODUCTION
EFFICIENCY



10.10.2019
Bietigheim-Bissingen
www.durr.com

Dürr Systems AG

Automation solutions for glazing and battery cover gluing

Dürr Systems AG
Carl-Benz Strasse 34
74321 Bietigheim-Bissingen

+49-7142-78-4145
michael.zoeller@durr.com

