



**Unipoint Flammable and Toxic Gas
Detection Controller**

1 Safety

Ensure that this manual is read and understood **BEFORE** installing / operating / maintaining the equipment.

WARNINGS

Unipoint is designed for installation and use in indoor safe area non-explosive atmospheres. Installation must be in accordance with the recognized standards of the appropriate authority in the country concerned.

Unipoint should be installed inside a lockable enclosure or in a secure location to prevent unauthorized access.

Before carrying out any work ensure local regulations and site procedures are followed. Work must only be conducted by trained personnel. Take any necessary precautions to prevent false alarms.

The detectors/sensors that the controller connects to may be used for gas detection in hazardous atmospheres. Refer to the individual detector/sensor instructions for their details.

The fault and alarm relay outputs may be used to switch voltages in excess of 50Vac. Ensure circuits have **DOUBLE** or **REINFORCED** insulation and are segregated in accordance with the voltage being switched and access is restricted to authorized personnel only.

Unipoint must be zero and span calibrated with the detector before operation.

Disposal should be according to local waste management requirements and environmental legislation. Alternatively contact your local Honeywell Analytics representative.

Honeywell Analytics can take no responsibility for installation and/or use of its equipment if this is not done in accordance with the appropriate issue and/or amendment of the manual. The reader of this manual should ensure that it is appropriate in all details for the exact equipment to be installed and/or operated. If in doubt, contact Honeywell Analytics for advice.

Every effort has been made to ensure the accuracy of our documents; however, Honeywell Analytics can assume no responsibility for any errors or omissions in our documents or their consequences. Honeywell Analytics greatly appreciates being informed of any errors or omissions that may be found in the contents of any of our documents. For information not covered in this document, or if there is a requirement to send comments/ corrections about this document, please contact Honeywell Analytics.

Honeywell Analytics reserve the right to change or revise the information supplied in this document without notice and without obligation to notify any person or organization of such revision or change. If information is required that does not appear in this document, contact the local distributor/agent or Honeywell Analytics.

2 Table of Contents

1 Safety.....	2
2 Table of Contents.....	3
3 Introduction	4
4 Installation.....	4
4.1 Mechanical Installation.....	4
4.2 Electrical Installation	6
4.2.1 Unipoint Controller Selection.....	6
4.2.2 Power Connection.....	6
4.2.3 Terminal Detail.....	7
4.2.4 Detector Types.....	7
4.2.5 Generic Detector Wiring Schematics	8
4.3 Maximum Cable Lengths	9
4.3.1 mA Detectors	9
4.3.2 mV Detectors	9
5 Default Configuration	10
5.1 Unipoint mV Input Version	10
5.2 Unipoint 4-20mA Input Version	10
6 Switch On.....	11
7 Initial Configuration	11
7.1 Setting Detector type (mA version only).....	12
8 Normal Operation.....	13
8.1 Display and Pushbutton Layout	13
8.2 Normal Operation LCD Event Codes	14
8.3 Display, Sounder and Relay Operation.....	14
8.4 Accept/Resetting Alarms.....	14
8.5 Fault Codes.....	15
8.6 Inhibit	15
8.7 Overrange	15
8.8 Self Test.....	15
9 Configuration.....	16
10 Ranges and Units	17
11 Alarm Relay On/Off Delay.....	17
11.1 Alarm Relay On Delay	17
11.2 Alarm Relay Off Delay	18
12 Maintenance	18
13 Ordering Information	19
14 Warranty Statement.....	19
15 Appendix A- Specification	20
16 Notes	21
17 Notes	22
18 Notes	23

3 Introduction

Unipoint is a self-contained single channel gas detection controller for use in indoor safe areas. It is designed for use with any mV flammable gas detector as well as any 2 wire or 3 wire 4-20mA source gas detector*. Unipoint is DIN rail mounted and displays gas concentration, alarm, fault and status information via its backlit LCD and LEDs, as well as providing a built in audible alarm. A keypad located below the display provides the facility to make changes to the system configuration. Unipoint is powered from 24VDC via the DIN rail. The detectors are connected to the controller via terminals on the side of the controller where terminals for remote inhibit/reset and output relays are also located.

There are two versions of Unipoint controller available. The mV version is for use with 3 wire mV flammable gas detectors such as the Signalpoint or Sensepoint range of flammable detectors. The 4-20mA version is for use with 2 wire and 3 wire 4-20mA source detectors such as the Signalpoint or Sensepoint range of toxic and oxygen detectors. It has 4 buttons: '▲' up, '▼' down, 'x' reset and '✓' OK, that are used to navigate through the menus and change the configuration settings.

*All Honeywell Analytics gas detectors and third party detectors subject to overall power requirements.

4 Installation

WARNING

Unipoint is designed for installation and use in indoor safe area non-explosive atmospheres. Installation must be in accordance with the recognised standards of the appropriate authority in the country concerned. Prior to carrying out any installation ensure local regulations and site procedures are followed. The detectors used with Unipoint are often designed for use in hazardous atmospheres. Refer to the individual detector instructions for details of their installation.

4.1 Mechanical Installation

Outline Dimensional Drawing

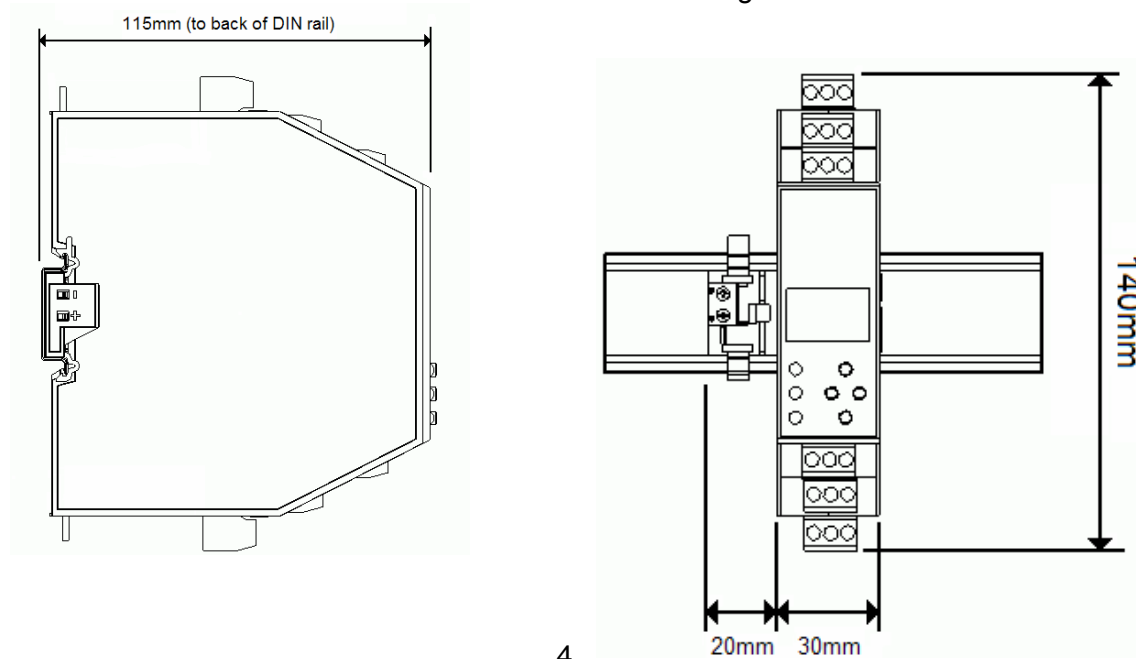

The Unipoint controller is mounted on standard symmetrical 'top hat' DIN Rail (35 x 7.5mm). To attach the Unipoint controller to the DIN rail follow the procedure below use the Installation Diagram as reference.

1. Clip the Unipoint controller socket on to the DIN rail (note the correct orientation from the diagram below).
2. Clip the power connector on to the DIN rail beside the controller socket.
3. Slide the connector and socket together until clip engages.
4. Attach the Unipoint Controller on to the socket by gently but firmly pushing it down onto the socket until it clips in place.
5. Additional Unipoint Controllers can be added to the DIN rail on the right hand side of the first unit. Clip additional controller sockets to rail and slide together until clips engage. Then attach the additional Unipoint Controllers.

Note: If mounting the Unipoint controller(s) inside an enclosure, ensure that the temperature inside the enclosure does not exceed the specified operating temperature.

Installation Drawing

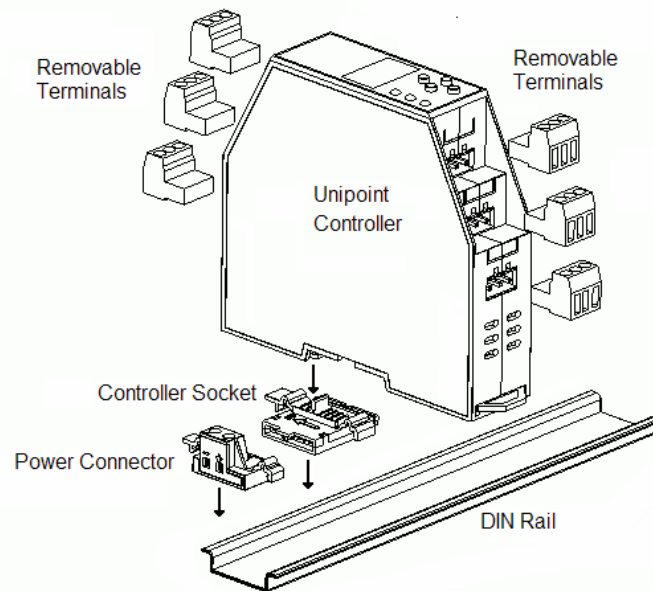

DIN Rail Drawing

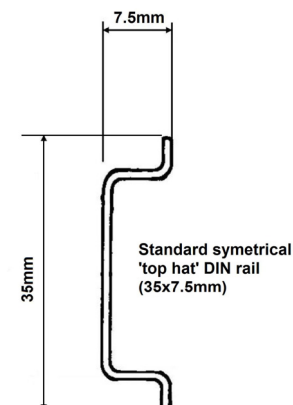

4.2 Electrical Installation

4.2.1 Unipoint Controller Selection

Detector	GasType	No. Wires	Unipoint Controller Required
Signalpoint	Flammable	3	mV
	Toxic	2	mA
Sensepoint	Flammable	3	mV
	Toxic	2	mA
Sensepoint Plus	Flammable	3	mA
	Toxic	3	mA
Sensepoint Pro	Flammable	3	mA
	Toxic	3	mA

4.2.2 Power Connection

Max number of Unipoint controllers on one DIN Bus

Detector type	Max number of controllers
3 wire mV	8
2 wire mA	8
3 wire mA	4

Unipoint Controller Maximum Power Consumption

Unipoint version	Controller status	Relays		Power
		Fault	Alarm	
mV	Normal operation, no faults, no alarms. Zero cable resistance	Energized	De energized	2.4W ¹
mV	Normal operation, no faults, no alarms. Max loop cable resistance (28 ohms)	Energized	De energized	3.6W ¹
mV	All alarms, no faults. Max cable resistance (28 ohms)	Energized	Energized	4.8W ¹
mA	Normal operation, no faults, no alarms. Inclusive of 2 wire signal loop current.	Energized	De energized	1.8W ²
mA	All alarms, no faults. Inclusive of 2 wire signal loop current.	Energized	Energized	3.0W ²

¹ includes power to detector

² excludes power to 3 wire mA detector.
All controllers with default configuration.

4.2.3 Terminal Detail

All electrical connections except power are made via removable terminals located on the top and bottom the controller. The power connection is made via the power connector attached to the DIN rail.

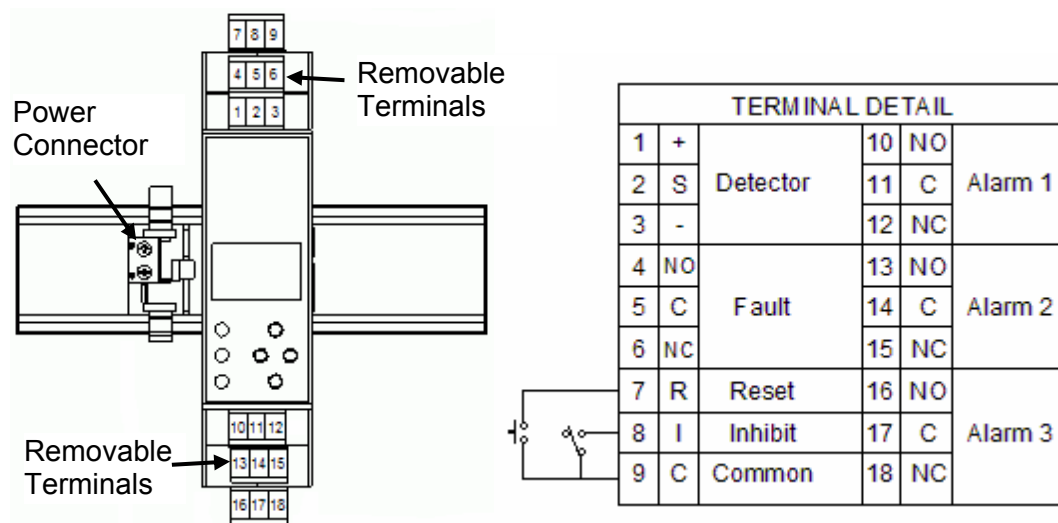

For security we recommend the use of a Key Switches for the remote reset and inhibit inputs mounted on the front of the enclosure in which the Unipoint is mounted.

4.2.4 Detector Types

Unipoint can accept signals from three types of detector. The table below summarizes the types of detector compatible with Unipoint.

Type of Detector	Output to Detector	Recommended Detector
2 wire 4-20mA	Controller Input (18-32Vdc)-1.5*Vdc, 30mA (max). Sense resistor 33 Ohms.	Signalpoint or Sensepoint Toxic and Oxygen
3 wire 4-20mA source	Controller Input (18-32Vdc)-1.5*Vdc, 0.5A (max). Sense resistor 33 Ohms.	Sensepoint Plus and Sensepoint Pro
3 wire mV bridge	2.4-8.6V, 200mA constant current. Max cable loop resistance 28 Ohms.	Signalpoint or Sensepoint Flammable

* Voltage drop in Unipoint Controller

4.2.5 Generic Detector Wiring Schematics

To connect the detector to the Unipoint use a 2 or 3 wire cable (as appropriate) that is suitably armoured (e.g. Steel Wire Armour) or conduit according to local requirements. Acceptable wire cross sectional area is from 0.5 to 1.5mm² with overall screen. Connect the screen to ground at the enclosure that the Unipoint is mounted in.

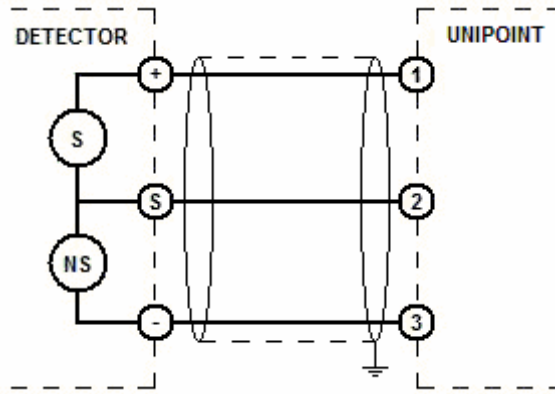

3 Wire mV Bridge

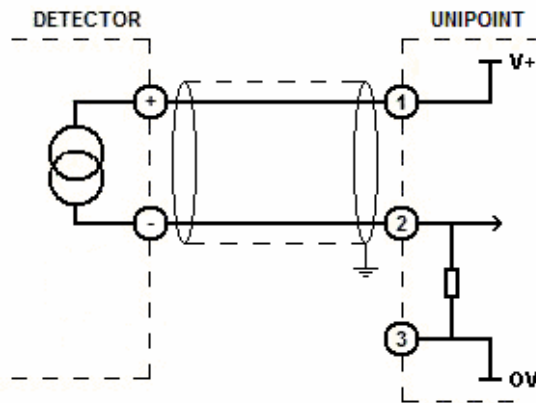

2 Wire 4-20mA

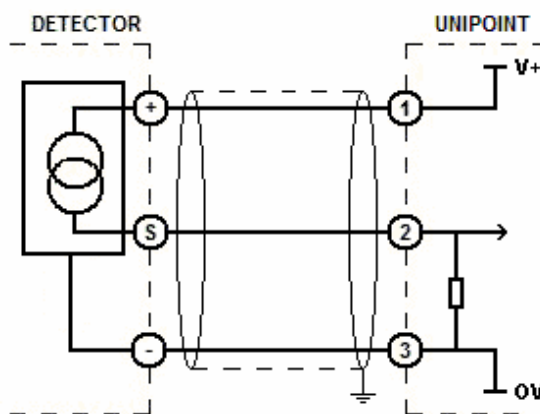

3 Wire 4-20mA Source

4.3 Maximum Cable Lengths

4.3.1 mA Detectors

To calculate the maximum cable run length from power source to the detector refer to the following example diagram and formula.

$$R_{loop} = (V_{controller} - 1.5V - V_{detector\ min}) / I_{detector}$$

Maximum cable run length = R_{loop} / cable per metre resistance where:

R_{loop} = maximum working cable loop resistance

$V_{controller}$ = maximum available supply voltage at controller

$V_{detector\ min}$ = minimum voltage at which the connected sensor can operate (sensor dependent, see individual sensor technical manual/data sheets)

$I_{detector}$ = sensor maximum drawn current. 30mA for 2 wire mA detectors. See individual detector technical manual/data sheets for max power consumption of 3 wire detectors.

4.3.2 mV Detectors

To calculate the maximum cable run length to the detector refer to the following typical example cable resistances. Max cable loop resistance = 28 ohms.

Solid Copper Conductor		
Cross Sectional Area		Maximum resistance at 20°C (ohm/loop km)
(mm ²)	AWG	
0.50	21	72
0.75	19	50
1.00	18	36
1.50	16	24
Stranded Copper Conductor		
Cross Sectional Area		Maximum resistance at 20°C (ohm/loop km)
(mm ²)	AWG	
0.50	21	73.6
0.75	19	49
1.00	18	35.2
1.50	16	23.4

5 Default Configuration

Unipoint has user configurable settings that allow the set up of the system to individual application requirements. Unipoint is supplied from the factory with a default configuration. These configurations are based on settings typically used in gas detection systems. Details of how to reconfigure Unipoint are given in section 8.

5.1 Unipoint mV Input Version

Function	Default configuration
Password	000 (Disabled)
Display range and units	0-100%LEL
Alarm Relay 1	Alarm level 1 10%LEL (Rising) Non-latching, normally de energized, energizes on alarm. Relay activation delay=0 seconds Relay de-activation hold=0 seconds (Single Pole change over, 240Vac/30Vdc, 3A max)
Alarm Relay 2	Alarm level 2 25%LEL (Rising) Non-latching, normally de energized, energizes on alarm. Relay activation delay=0 seconds Relay de-activation hold=0 seconds (Single Pole change over, 240Vac/30Vdc, 3A max)
Alarm Relay 3	Alarm level 3 50%LEL (Rising) Latching, normally de energized, energizes on alarm. Relay activation delay=0 seconds Relay de-activation hold=0 seconds (Single Pole change over, 240Vac/30Vdc, 3A max)
Fault Relay	Non-latching, normally energized, de-energizes on fault. (Single Pole change over, 240Vac/30Vdc, 3A max)
Inhibit	Controller inhibit activates fault relay.

5.2 Unipoint 4-20mA Input Version

Function	Default configuration
Password	000 (Disabled)
Display range and units	0-100ppm
Current input	0 mA Fault (open circuit) 4.0 to 20.0mA Gas reading (normal operation) 1.5 to 2.5mA Inhibit from sensor (configuration mode) >20.0mA Overrange
Alarm Relay 1	Alarm level 1 10% of full scale (Rising) Non-latching, normally de energized, energizes on alarm. Relay activation delay=0 seconds Relay de-activation hold=0 seconds (Single Pole change over, 240Vac/30Vdc, 3A max)
Alarm Relay 2	Alarm level 2 25% of full scale (Rising) Non-latching, normally de energized, energizes on alarm. Relay activation delay=0 seconds Relay de-activation hold=0 seconds (Single Pole change over, 240Vac/30Vdc, 3A max)
Alarm Relay 3	Alarm level 3 50% of full scale (Rising) Non-latching, normally de energized, energizes on alarm. Relay activation delay=0 seconds Relay de-activation hold=0 seconds (Single Pole change over, 240Vac/30Vdc, 3A max)
Fault Relay	Non-latching, normally energized, de-energizes on fault. (Single Pole change over, 240Vac/30Vdc, 3A max)
Inhibit	Controller inhibit activates fault relay and de-activates alarm relays. Field inhibit active (1.5 to 2.5mA on detector input).
Detector Type	2 Wire 4-20mA

6 Switch On

After connecting power, the controller enters a self test routine: All LCD segments flash, the fault and alarm LED flash, the sounder operates three times, the RAM, ROM and EEPROM are checked and the software version is displayed. If no faults are found (see section 7.5 for fault codes) the unit enters a detector warm up period indicated by a count down from 60 to 0 on the display. During this time the controller is inhibited ('Inh') so all alarms and faults are inactive.

At the end of the warm-up period the controller checks for detector and field wiring faults. If a fault is found, the fault code is displayed (see section 7.5 for fault codes). If no fault is found the controller enters normal operation and will display current gas reading and alarm(s) if appropriate.

7 Initial Configuration

WARNING

Unipoint must be zero and span calibrated with the detector before operation.

If the default configuration shown in section 5.1 (mV type controller) or 5.2 (mA type controller) does not match the application requirements, follow the procedures below to reconfigure the controller.

Notes: If using a mA version controller with a 3 wire mA type detector, carry out the procedure in section 7.1 first to set the correct detector type.

If configuring the controller for use with an Oxygen detector, skip the 'Set zero' instructions (steps 7-14) and use 20.9% (background air oxygen level) as the span calibration point.

After completing all the steps in a menu, the ✓ button must be pressed to save the changes. Press x at any time to ignore the changes made in the current menu.

1. Press the ▲▼ buttons together to enter the configuration mode.
2. Press ✓ to enter the 'Set Range and Units (FS)' menu.
3. The default range flashes. Press the ▲▼ buttons to select the required range.
4. Press ✓ to set the new range.
5. The default units start flashing. Press the ▲▼ buttons to select the required units.
6. Press ✓ to set the new units. (See section 9 for available ranges and units).
7. Press the ▼ button to select the 'Set Zero (0)' menu.
8. Press ✓ to enter the 'Set Zero (0)' menu.
9. The current zero gas reading is displayed.
10. Apply zero gas to the detector.
11. Press ✓ when the reading is stable.
12. The display will show '---' while calculating the zero point and then '0' when complete. If the zero fails 'FFF' is displayed.
13. Remove the zero gas from the detector.
14. Press ✓ to complete the zero calibration.
15. Press the ▼ button to select the 'Set Span (S)' menu.
16. Press ✓ to enter the 'Set Span (S)' menu.
17. 50% of the set range flashes.

18. Press ▲▼ buttons to set the concentration of the span calibration gas concentration being used.
19. Press ✓ to set the span calibration concentration.
20. Apply the span calibration gas to the detector.
21. The 'live' gas reading is displayed.
22. If the reading is too low 'S-L' is displayed, if too high 'S-H' is displayed.
23. When the reading is stable press ✓.
24. '---' is displayed while calculating the new span.
25. The display then shows the new span value. If span fails 'FFF' is displayed.
26. Remove the span gas from the detector and allow the display to return to zero.

Note: Allowing the reading to return to zero before exiting ensures no accidental alarms are triggered.

27. Press ✓ to return to the menu.
28. Press the ▼ button to select the 'Set Alarms (A1)' menu.
29. Press ✓ to enter the 'Set Alarms (A1)' menu.
30. The current alarm 1 set point flashes.
31. Press ▲▼ buttons to change the A1 set point.
32. Press ✓ to confirm.
33. The display shows the current alarm relay on delay in seconds.
34. Press ▲▼ buttons to change the alarm relay on delay.
35. Press ✓ to confirm.
36. The display shows the current alarm relay off (hold) delay in seconds.
37. Press ▲▼ buttons to change the alarm relay off delay.
38. Press ✓ to confirm.
39. The display shows the current alarm 1 relay configuration.
40. Press ▲▼ buttons to select either 'F' for falling or 'r' for rising alarm point.
41. Press ✓ to confirm.
42. Press ▲▼ buttons to select either 'E' for normally energized or 'd' for normally de-energized relay.
43. Press ✓ to confirm.
44. Press ▲▼ buttons to select either 'L' for latching or 'n' for non-latching relay.
45. Press ✓ to confirm.
46. The display now shows the current alarm 2 level.
47. Repeat steps 28 to 43 for alarm 2 and then alarm 3.
48. Press 'x' to return to normal operation.

Note: For details of other settings in the configuration menu refer to section 8.

7.1 Setting Detector type (mA version only)

The default detector type setting for a mA version controller is 2 wire. If using a 3 wire mA type detector carry out the procedure below:

1. Press the ▲▼ buttons together to enter the configuration mode.
2. Press ▲ or ▼ buttons to select the 'Detector Type (IP)' menu.
3. The current detector input type flashes (2L=2 wire mA).
4. Press the ▲▼ buttons to select 3L=3 wire mA).
5. Press ✓ to confirm.
6. Press x to return to normal operation.
7. Follow the procedures in section 7 to complete the initial configuration.

8 Normal Operation

In normal operation the green Power LED is illuminated and the 1st line of the LCD shows the current gas reading. The 2nd line is used to display text codes that provide additional information about the type of event that has occurred. An alarm, fault/inhibit LED and built in sounder are also used when signaling events.

8.1 Display and Pushbutton Layout

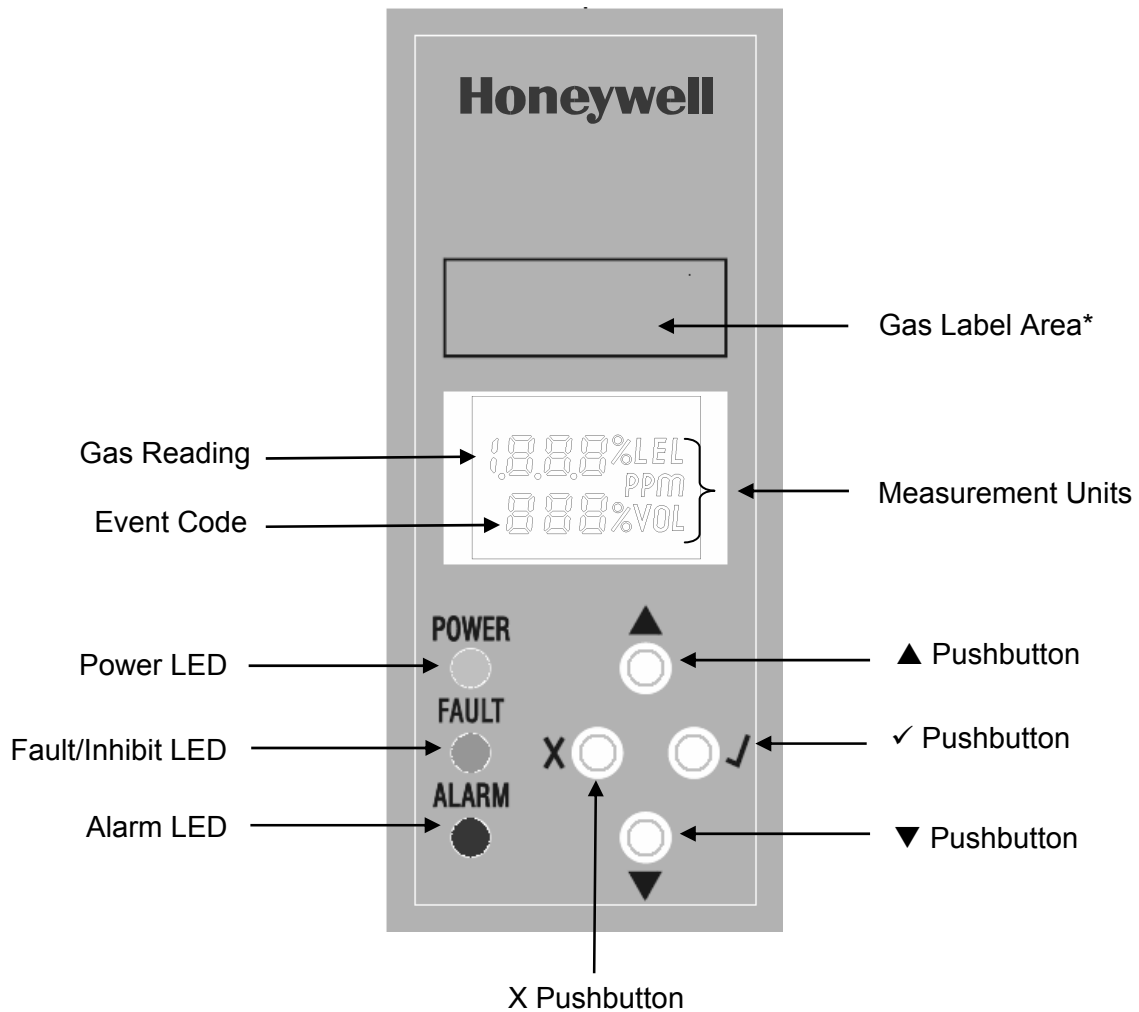

*A packet of stick on gas labels are supplied with each Unipoint Controller

8.2 Normal Operation LCD Event Codes

The display event codes are shown below:

NORMAL OPERATION DISPLAY TEXT CODES			
CODE			EVENT TYPE
A	-	1	Alarm point 1 exceeded
A	-	2	Alarm point 2 exceeded
A	-	3	Alarm point 3 exceeded
O	F	F	All outputs disabled
F	X	X	Fault. XX=Fault code
I	n	h	Remote or field* inhibit

*only available on mA version (see section 7.6 for further details).

8.3 Display, Sounder and Relay Operation

The table below shows the default operation of the display, sounder and relays for given events.

EVENT	LCD	LEDS*		SOUNDER	RELAY			
		ALARM	FAULT/INH		A1	A2	A3	F
Alarm 1 threshold exceeded	A-1	flashing	off	on	X			
Alarm 2 threshold exceeded	A-2	flashing	off	on	X	X		
Alarm 3 threshold exceeded	A-3	flashing	off	on	X	X	X	
Fault	FXX	off	flashing	on				X
Inhibit	Inh	off	flashing	off				X
Overrange	Or/A3	flashing	off	on	X	X	X	

*LED flash frequency: Alarm = 2Hz, Fault = 1Hz and Inhibit = 0.5Hz

8.4 Accept/Resetting Alarms

In normal operation, the X button on the controller front panel or a switch connected to the remote reset terminal is used to reset/accept alarm events. The effect of reset/accept dependent on gas reading and alarm latching setting is described below:

	Gas reading still exceeds alarm threshold	Gas reading below alarm threshold
Latched alarm	Sounder stops. Flashing alarm LED changes to steady. Gas reading and alarm code displayed on LCD. Alarm relay remains in alarm state.	Sounder stops. Alarm LED is turned off. The LCD alarm code clears. Alarm relay returns to original state.
Unlatched alarm	Sounder stops. Flashing alarm LED changes to steady. Gas reading and alarm code displayed on LCD. Alarm relay remains in alarm state.	Alarm indications and relay operation reset automatically without need for reset/accept.

Note: If the controller is in inhibit when an alarm threshold is exceeded the alarm LED only will operate. See section 10 for details of how the relay delay and hold function effects the operation of the unit.

8.5 Fault Codes

Below are the fault codes and recommended action to clear the fault.

FAULT CODE			DESCRIPTION	TROUBLE SHOOT
F	-	S	Sensor / wiring fault	Check sensor / field wiring
F	N	D	Negative drift	Calibrate detector
F	I	F	Excessive interference	Check field wiring
F	R		RAM fault	Replace controller
F	C		Memory failure	Replace controller
F	E		Configuration error	Replace controller

8.6 Inhibit

The controller is put into inhibit via a normally open switch connected to the inhibit terminal or when entering configuration mode. The inhibit is maintained until the switch is opened again or on return to normal operation mode.

Additionally, an inhibit signal of between 1.5mA to 2.5mA can be signaled to the controller from a field device. This facility is only available on mA version controllers (see section 8).

When in inhibit the alarm relay and sounder do not operate. The alarm LED will operate if the alarm threshold is exceeded. The 2nd line of the LCD will show Inh (except in configuration mode where a slow flashing fault LED indicates the inhibit).

The controller can also be disabled using the disable function in the configuration mode (see section 8).

See section 10 for details of how the relay delay and hold function is effected by inhibit.

8.7 Overrange

When the gas reading exceeds full scale 'Or' replaces the gas reading to indicate an overrange condition. The 2nd line of the LCD continues to show the alarm state. If alarm level 3 is configured latching then the overrange condition will also latch (default for 3 wire mV version).

8.8 Self Test

The controller enters a self test routine at power on. It can also be forced into a self test by pressing the ✓ button in normal operation. The controller automatically conducts a self test at regular intervals.

9 Configuration

From normal mode press the **▲▼** buttons together to enter configuration mode. If no password has been set the display will go directly to the menu selection. If a password has been set then the display will show '000' and the 1st digit will flash. Press **▲▼** to change the first digit of the password. Press **✓** to move to the next digit. Repeat to set the 2nd and 3rd digits of the password. Press **x** at any time to exit and return to normal mode. Press **✓** after setting the 3rd digit to confirm the password and enter the menu selection. If the password entered is incorrect the display will return to normal mode. Use the table below to help navigate the menu and make configuration changes.

▲▼	OK	▲▼	OK	▲▼	OK	▲▼	OK	▲▼	OK
RANGE AND UNITS (FS)*	✓	RANGE FLASHES. PRESS ▲▼ TO SELECT NEW RANGE	✓	UNITS FLASH. PRESS ▲▼ TO SELECT NEW UNITS.	✓	NEW RANGE AND UNITS SETTINGS CONFIRMED. RETURNS TO MAIN MENU	OK	▲▼	OK
SET ZERO (0)**	✓	CURRENT ZERO GAS READING DISPLAYED. APPLY ZERO GAS.	✓	'L-' DISPLAYED WHILE MEASURING THEN ZERO READING DISPLAYED. IF ZERO FAILS 'FFF' IS DISPLAYED. REMOVE GAS.	✓	NEW ZERO SETTING CONFIRMED. RETURNS TO MAIN MENU			
SET SPAN (S)**	✓	50% OF RANGE FLASHES. PRESS ▲▼ TO SET CAL GAS CONCENTRATION	✓	APPLY CALIBRATION GAS. LIVE GAS READING DISPLAYED. 'S-L' IF TOO LOW, 'S-H' IF TOO HIGH.	✓	'L-' DISPLAYED WHILE MEASURING THEN NEW SPANMED READING. IF SPAN FAILS 'FFF' IS DISPLAYED. REMOVE GAS	✓	NEW SPAN SETTING CONFIRMED. RETURNS TO MAIN MENU	
SET ALARMS (A1, A2, A3)	✓	CURRENT ALARM 1 SET POINT FLASHES. PRESS ▲▼ TO CHANGE.	✓	PRESS ▲▼ TO SELECT ALARM ON DELAY (0 to 900 secs)	✓	PRESS ▲▼ TO SELECT ALARM OFF DELAY (0 to 900 secs)	✓	ALARM 1 RELAY CONFIGURATION DISPLAYED. PRESS ▲▼ TO SELECT 'F'=FALLING OR 'R'=RISING	✓
SET FAULT RELAY (F)	✓	PRESS ▲▼ TO SELECT 'E'=ENERGIZED OR 'd'=DE-ENERGIZED.	✓	PRESS ▲▼ TO SELECT 'L'=LATCHING OR 'n'=NON-LATCHING	✓	NEW ALARM SETTINGS CONFIRMED. RETURNS TO MAIN MENU. REPEAT FOR ALARM 2 & 3.			
SET FAULT RELAY (F)	✓	FIRST FAULT RELAY SETTING FLASHES. PRESS ▲▼ TO SELECT 'E'=ENERGIZED OR 'd'=DE-ENERGIZED.	✓	PRESS ▲▼ TO SELECT 'F'=FAULT RELAY ACTION ON INHIBIT OR 'in'=NO ACTION ON INHIBIT.	✓	NEW FAULT RELAY SETTINGS CONFIRMED. RETURNS TO MAIN MENU			
SET PASSWORD (PAS)	✓	FIRST DIGIT OF CURRENT PASSWORD FLASHES. PRESS ▲▼ TO CHANGE FIRST DIGIT.	✓	SECOND DIGIT OF PASSWORD FLASHES. PRESS ▲▼ TO CHANGE SECOND DIGIT.	✓	THIRD DIGIT OF PASSWORD FLASHES. PRESS ▲▼ TO CHANGE THIRD DIGIT.	✓	NEW PASSWORD CONFIRMED. RETURNS TO MAIN MENU	
DISABLE (dis)	✓	DISPLAY SHOWS 'dis'	✓	LOWER LINE OF DISPLAY SHOWS 'OFF'. PRESS X AND ✓ SIMULTANEOUSLY FOR >1 SECOND TO TAKE UNIT OUT OF INHIBIT.					
FIELD INHIBIT (Fih)***	✓	PRESS ▲▼ TO SELECT 'inh'=DETECTOR INHIBIT ON OR 'fal'=FOR DETECTOR INHIBIT OFF	✓	DETECTOR INHIBIT SETTING CONFIRMED. RETURNS TO MAIN MENU.					
DETECTOR TYPE (IP)***	✓	CURRENT DETECTOR INPUT TYPE FLASHES. PRESS ▲▼ TO SELECT '2L'=2 WIRE mA OR '3L'=3 WIRE mA	✓	DETECTOR INPUT SETTING CONFIRMED. RETURNS TO MAIN MENU.					
▲▼	OK	▲▼	OK	▲▼	OK	▲▼	OK	▲▼	OK

NOTES:

Detector inhibit signal range = 1.5mA to 2.5mA.

All steps in the respective menu option must be completed and **✓** pressed for the changes to be saved. Pressing **X** before confirmation of new settings returns to main menu with no changes to configuration.

*See section 9 for available ranges and units.

**If configuring the controller for use with an Oxygen detector, skip the 'Set zero' instructions and use 20.9% (background air oxygen level) as the span calibration point.

***Only available on mA input version

10 Ranges and Units

Below are the possible combinations of range and units for the two Unipoint Controller types:

Unipoint Controller	Units	Available Full Scale Ranges
mV or mA version	%LEL %VOL	2.00, 3.00, 5.00, 10.0, 15.0, 20.0, 25.0, 50.0 or 100
	PPM	2.00, 3.00, 5.00, 10.0, 15.0, 20.0, 25.0, 50.0, 100, 150, 200, 300, 400, 500 or 1000

11 Alarm Relay On/Off Delay

Part of the 'Set Alarms' configuration allows a user programmable delay for each alarm threshold between the detection of an alarm and the activation of the alarm relay output, and a programmable hold between the clearing of an alarm and the release of the relay output. The delay times are adjustable over the range 0 to 900 seconds (900sec equals 15mins). The default delay times are 0 (no delay).

WARNING

If an alarm relay activation delay set to greater than 0 secs the presence of a gas concentration in excess of the alarm threshold will not be immediately signaled.

11.1 Alarm Relay On Delay

The programmable alarm relay delay operates in the following manner:

- If the delay is set, then in the event of the **GAS CONCENTRATION EXCEEDING** the alarm threshold the following occurs:
 - The LCD, LED, and buzzer signal the alarm.
 - The alarm relay output does not signal the occurrence of the alarm immediately.
 - The delay counts down.
 - When the delay has expired, the relay output then signals the alarm.
- If during the delay the **GAS CONCENTRATION FALLS** below the alarm threshold and the alarm is configured as **NON-LATCHING**, the indication of the alarm on the LCD, LED, and buzzer is removed and the delay reset.
- If during the delay the gas **CONCENTRATION FALLS** below the alarm threshold and the alarm is configured as **LATCHING**, the indication of the alarm on the LCD, LED, and buzzer remains, the delay continues to run and the relay output is updated when the delay time has expired.
- If during the delay the **GAS CONCENTRATION IS ABOVE** the alarm threshold and the **ACCEPT/RESET INPUT/KEY** is activated to accept the alarm, the LCD, LED, and buzzer will respond as per section 7.4, the delay continues to run and the relay output is updated when the delay time has expired.
- If during the delay the **GAS CONCENTRATION FALLS BELOW** the alarm threshold, the alarm is configured as **LATCHING**, and the **ACCEPT/RESET EXTERNAL INPUT/KEY** is activated to reset the alarm, the LCD, LED, buzzer and the delay time reset.

- If during the delay the unit is placed into **INHIBIT** by either the external inhibit or by entering the configuration mode, the delay will be reset. On exiting the inhibit mode the relay output will be updated.
- If during the delay a **FAULT** is signaled, the delay will continue and the relay output updated when the delay time has expired. (The alarm will continue to be signaled on the sounder, LED, and LCD after the fault occurs. The relay output will be updated to reflect the alarm when the time expires.)

11.2 Alarm Relay Off Delay

The programmable alarm relay hold operates in the following manner.

- If the hold time is set, then in the event of the **GAS CONCENTRATION FALLING** below the alarm threshold after previously exceeding the alarm threshold for a period of time greater than the delay time (i.e. the relay output is reflecting the active alarm) and the alarm threshold is configured as **NON-LATCHING** the following occurs:
 - The LCD, LED, and buzzer will stop signaling the alarm.
 - The alarm relay does not signal the absence of the alarm immediately.
 - The hold time counts down.
 - When the hold time expires, the relay output is updated to signal the absence of the alarm.
- If during the hold time the gas **CONCENTRATION RISES** back above the alarm threshold, the LCD, LED, and buzzer signal the re-occurrence of the alarm and the hold time is reset.
- If during the hold time the **ACCEPT/RESET EXTERNAL INPUT/KEY** is activated, the relay output is updated immediately.
- If during the hold time the unit is placed into **INHIBIT** by either the external inhibit or by entering the configuration mode, the hold time is reset. On exiting the inhibit mode the relay output is updated immediately.
- If during the hold time a **FAULT** is signaled, the hold time is reset and the relay output is updated immediately.
- If the alarm is configured as **LATCHING**, the hold time has no affect upon the operation of the unit. i.e. The signaling of a latched alarm via the relay output will removed immediately the accept/reset external input/key is activated.

12 Maintenance

The Unipoint controller has no user serviceable parts. Honeywell Analytics recommend that the controller's configuration and operation are checked annually.

The gas detectors connected to the controller should be checked and if necessary zero and span calibrated by following the procedures detailed in their user guides.

13 Ordering Information

Unipoint Controllers

Unipoint Controller (mV input version) 2306B2000

Unipoint Controller (mA input version) 2306B1000

Spares

Unipoint Terminal Block Plug (x2) 2306B3010

Unipoint DIN rail socket kit 2306B3020

Unipoint power connector kit 2306B3030

14 Warranty Statement

All products are designed and manufactured to the latest internationally recognized standards by Honeywell Analytics under a Quality Management system that is certified to ISO 9001. As such Honeywell Analytics warrants its products against defective parts and workmanship and will repair or (at its option) replace any instruments which are or may become defective under proper use within 12 months from date of commissioning by an approved Honeywell Analytics representative or 18 months from date of shipment from Honeywell Analytics, whichever is the sooner. This warranty does not cover disposable batteries or damage caused by accident, abuse, abnormal operating conditions or poisoning of sensor.

Defective goods must be returned to Honeywell Analytics premises accompanied by a detailed description of any issue. Where return of goods is not practicable Honeywell Analytics reserves the right to charge for any site attendance where any fault is not found with the equipment. Honeywell Analytics shall not be liable for any loss or damage whatsoever or howsoever occasioned which may be a direct or indirect result of the use or operation of the Contract Goods by the Buyer or any Party.

This warranty covers instrument and parts sold to the Buyer only by authorized distributors, dealers and representatives as appointed by Honeywell Analytics. The warranties set out in this clause are not pro rata, i.e. the initial warranty period is not extended by virtue of any works carried out there under.

15 Appendix A- Specification

Specification				
Use	The Zareba Unipoint controller provides integrators with a flexible and low cost solution to the many applications requiring flammable, toxic or oxygen gas detection to be incorporated into their control systems. Unipoint is designed to use industry standard DIN rail allowing it to be easily installed into many different types of plastic or metal, indoor or outdoor, hazardous or non hazardous area enclosures. It is designed for use with any mV flammable gas detector as well as any 2 or 3 wire 4-20mA gas detector (subject to overall power requirements).			
User interface				
Operation	Two pushbuttons for normal operation of resetting alarms and initiating self diagnostic test of system. Four buttons for user programmable functions via intuitive menu			
Backlit display	Units of measure, digital gas reading and event code			
Other indication	Ultra-bright steady/flashing LEDs subject to condition; alarm (red), power (green), fault (amber). In-built audible alarm 63dB at 0.3 meters.			
Termination	Easily accessible plug in screw type terminals. Terminals accept maximum wire diameter 1.5mm ²			
Environmental				
IP rating	IP30 (Install in suitable enclosure)			
Weight	225g (Controller only)			
Operational Temperature Humidity Pressure	-10°C to +55°C / 14°F to 131°F 10 to 90%RH (non condensing) 90-110kPa			
Storage	-25°C to +60°C / -13°F to +140°F, 20 to 80%RH (non condensing)			
Inputs				
Supply	Nominal 24Vdc (18-32Vdc). Max power mV = 4.8W (including power to detector), mA= 3.0W (excluding power to 3 wire detector).			
Detector type	3 wire mV bridge e.g. Sensepoint or Signalpoint flammable gas detectors	2 wire, 4-20mA, loop powered e.g. Sensepoint or Signalpoint toxic or oxygen gas detectors	3 wire, 4-20mA, source output e.g. Sensepoint Plus and Pro flammable, toxic and oxygen gas detectors	
Detector supply	2.4-8.6V, 200mA constant current. Maximum loop resistance: 28 Ohms	Input (18-32Vdc)-1.5Vdc, 30mA max.	Input (18-32Vdc)-1.5Vdc, 0.5A max.	
Outputs				
Relays	Alarm 1	Alarm 2	Alarm 3	Fault
Rating	SPCO / 3A, 240Vac/30Vdc (non inductive load)	SPCO / 3A, 240Vac/30Vdc (non inductive load)	SPCO / 3A, 240Vac/30Vdc (non inductive load)	SPCO / 3A, 240Vac/30Vdc (non inductive load)
Default setting	Non Latching Normally de- energized Energize on alarm Factory setting 10%FSD	Non Latching Normally de- energized Energize on alarm Factory setting 25%FSD	Latching (mV) Non Latching (mA) Normally de- energized Energize on alarm Factory setting 50%FSD	Non Latching Normally energized De-energize on fault/power loss
User configurable options	Latching/non-latching Energized/de- energized Alarm trip point Rising/falling Alarm on / off delay (0 to 900 seconds)	Latching/non-latching Energized/de- energized Alarm trip point Rising/falling Alarm on / off delay (0 to 900 seconds)	Latching/non-latching Energized/de- energized Alarm trip point Rising/falling Alarm on / off delay (0 to 900 seconds)	Latching/non-latching Energized/de- energized
Approvals				
EMC/RFI	EN50270			
Electrical safety	EN61010			
Performance	ATEX measuring function EN61779 (Independent accreditation in progress). Check product label for ATEX certificate number.			
Other	CE, TUV.			

16 Notes

17 Notes

18 Notes

Find out more

www.honeywellanalytics.com

Customer business centre

Europe and the rest of the world

Honeywell Analytics AG

Wilstrasse 11-U11

CH-8610 Uster

Switzerland

Tel: +41 (0)44 943 4300

Fax: +41 (0)44 943 4398

sales@zelana.co.uk

Customer business center

Americas

Honeywell Analytics Distribution, Inc.

400 Sawgrass Corporate Pkwy

Suite 100

Sunrise, FL 33325

USA

Tel: +1 954 514 2700

Toll free: +1 800 538 0363

Fax: +1 954 514 2784

sales@zelana.com

www.honeywell.com

Please Note:

While every effort has been made to ensure accuracy in this publication, no responsibility can be accepted for errors or omissions.

Data may change, as well as legislation, and you are strongly advised to obtain copies of the most recently issued regulations, standards, and guidelines. This publication is not intended to form the basis of a contract.

© 2005 Honeywell Analytics

Issue 6 7/2006

H_MAN0638_V3

2306-M-5001

© 2006 Honeywell Analytics

Honeywell